

ENGINE, RIGHT VIEW - Models H, 3H, 4H

ENGINE

Plate 01-2

Plate 01-5

ENGINE

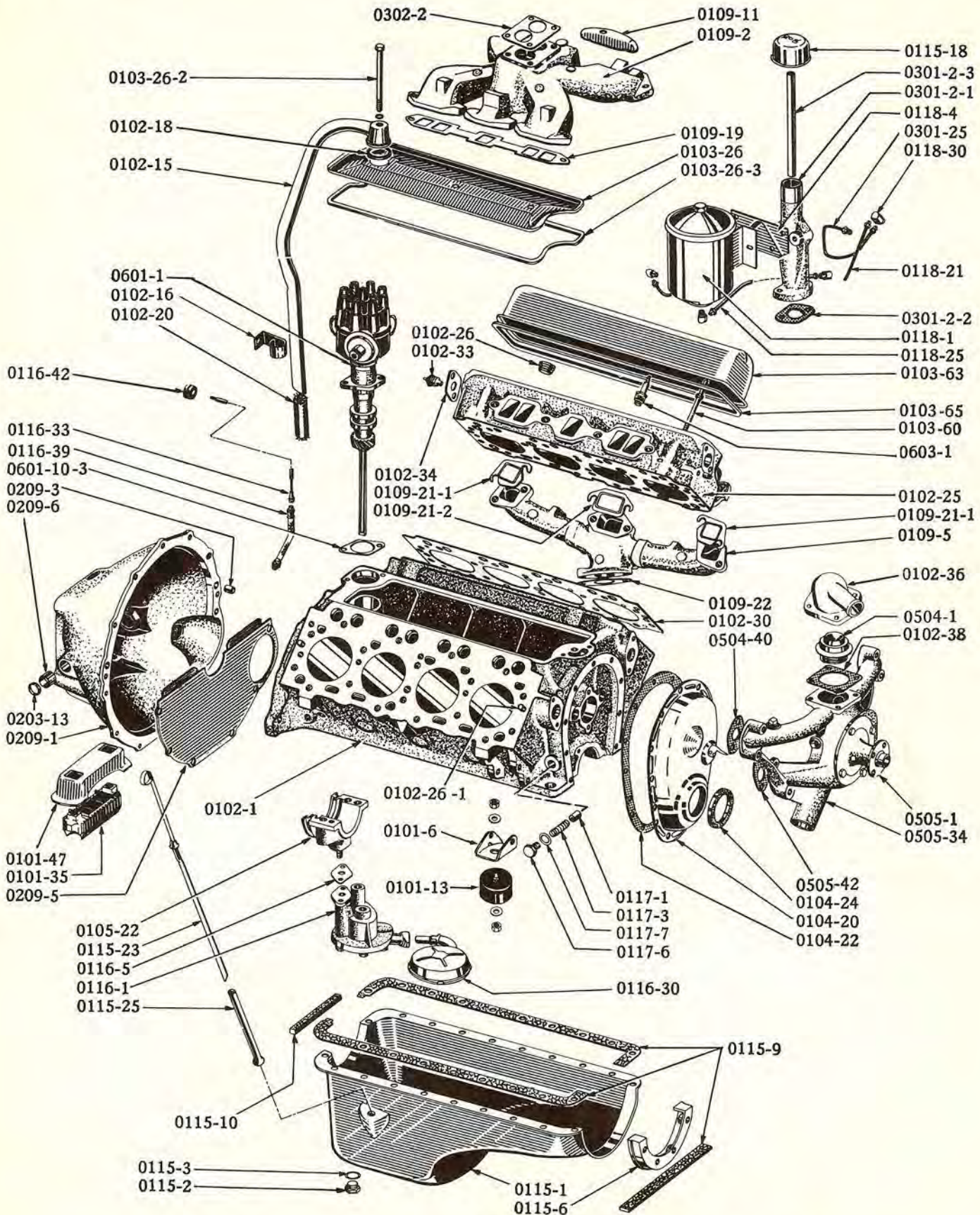

ENGINE EXTERNAL PARTS - Models H, 3H, 4H

ENGINE

Plate 01-6

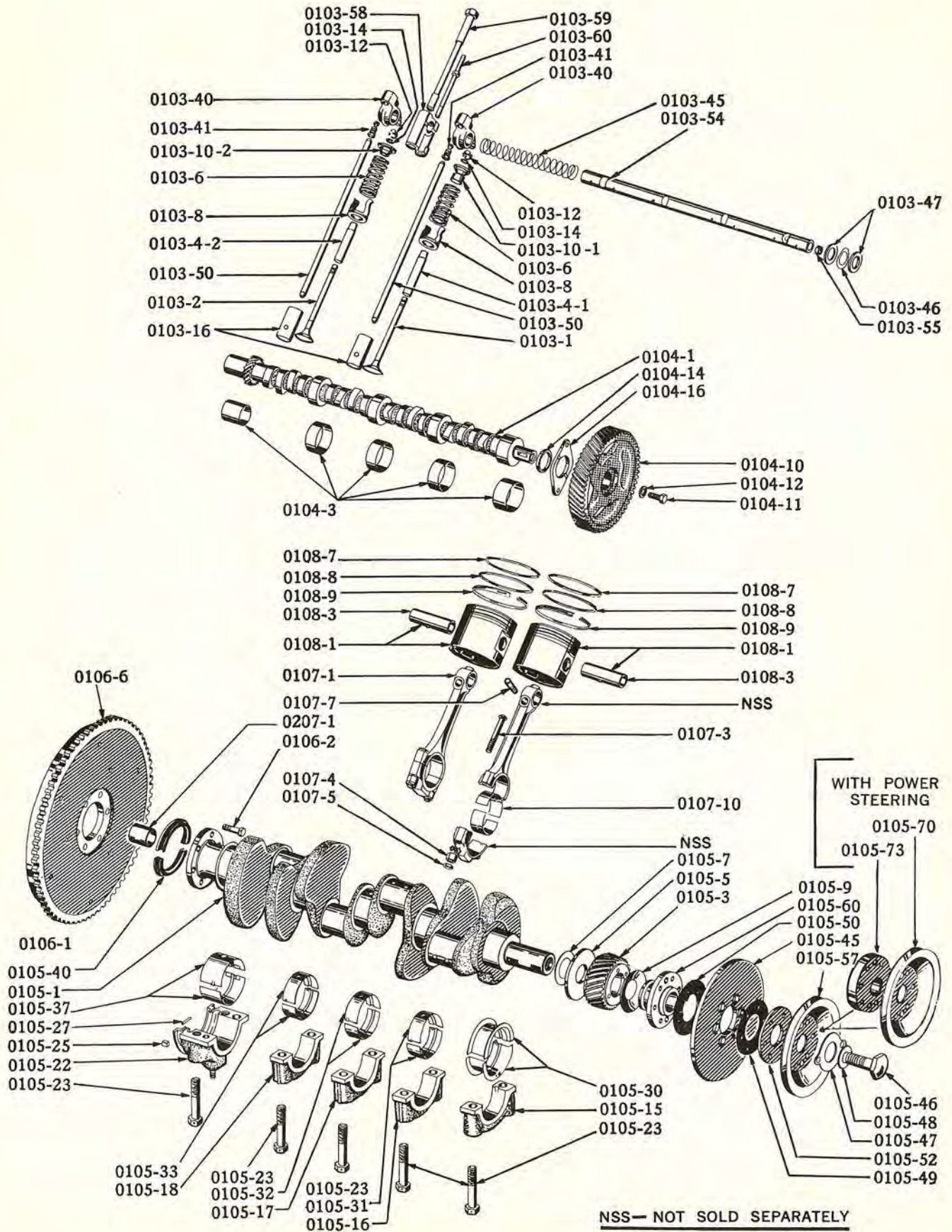

ENGINE INTERNAL PARTS - Models H, 3H, 4H

Plate 01-7

ENGINE

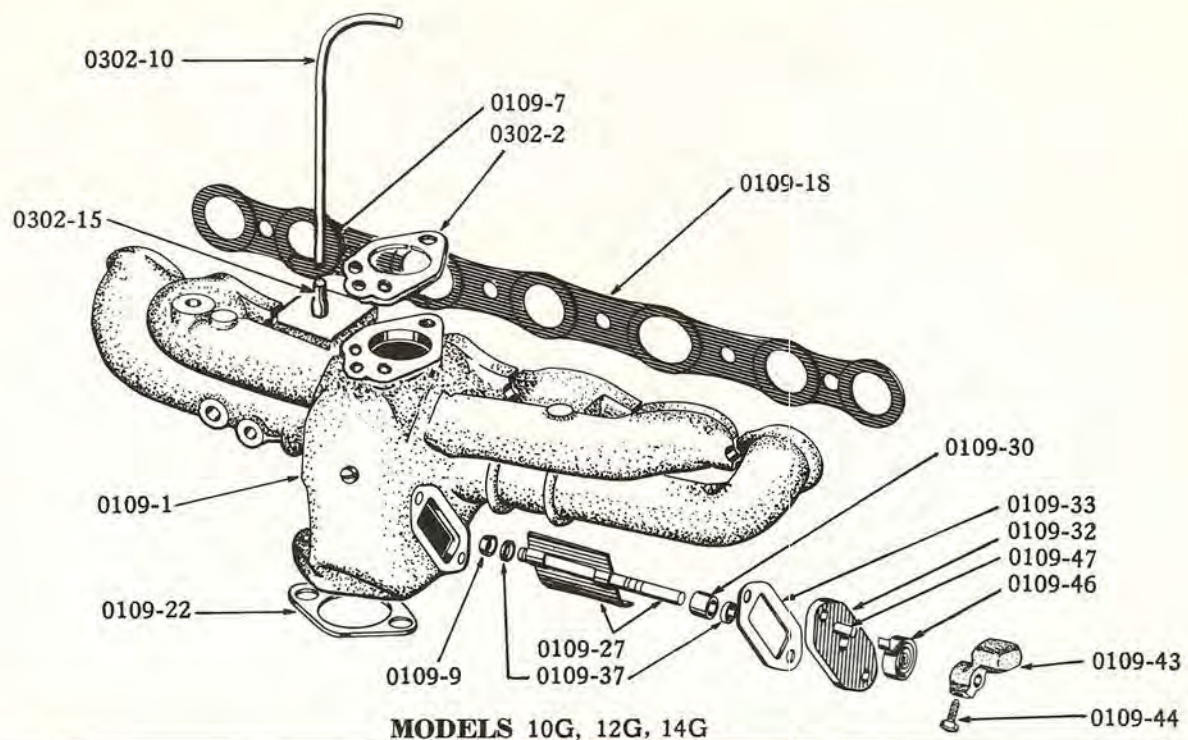

MODELS 10G, 12G, 14G

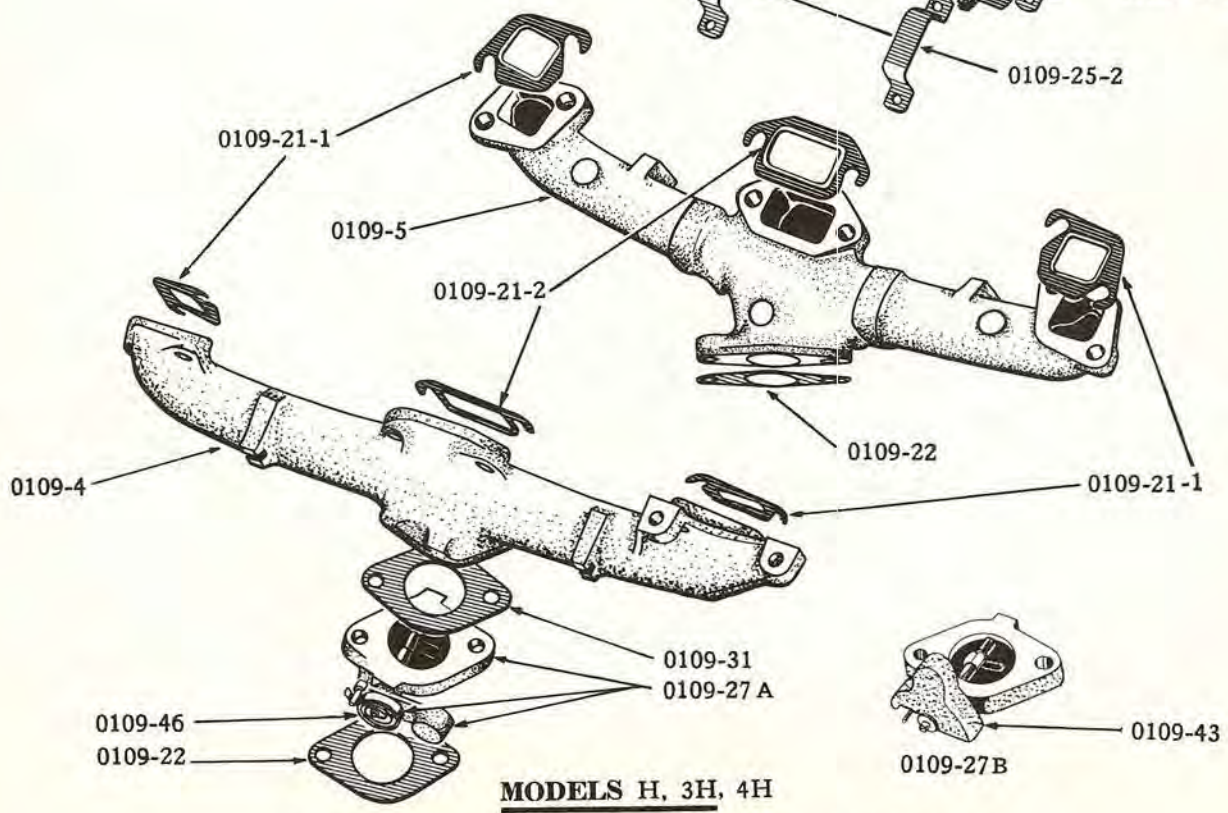
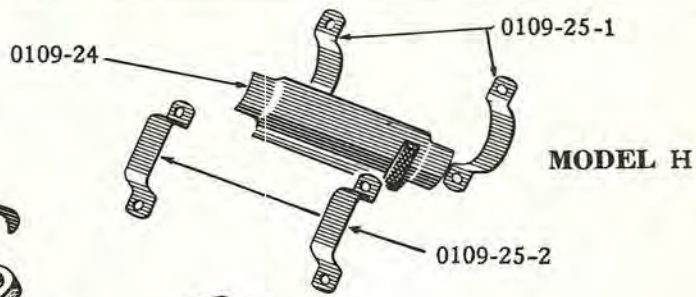

MODELS H, 3H, 4H

MANIFOLDS and HEATER VALVES

ENGINE

Plate 01-8

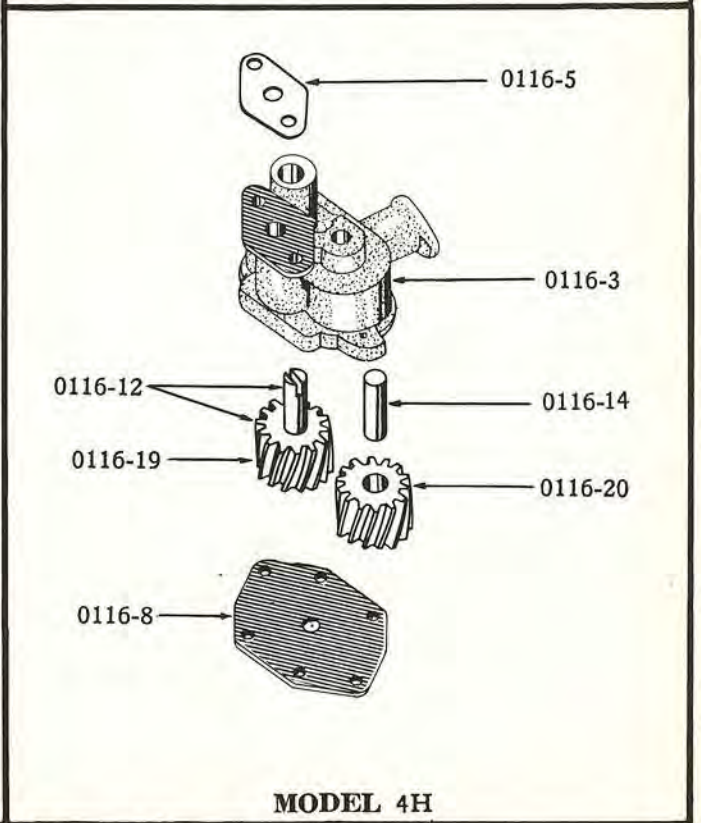
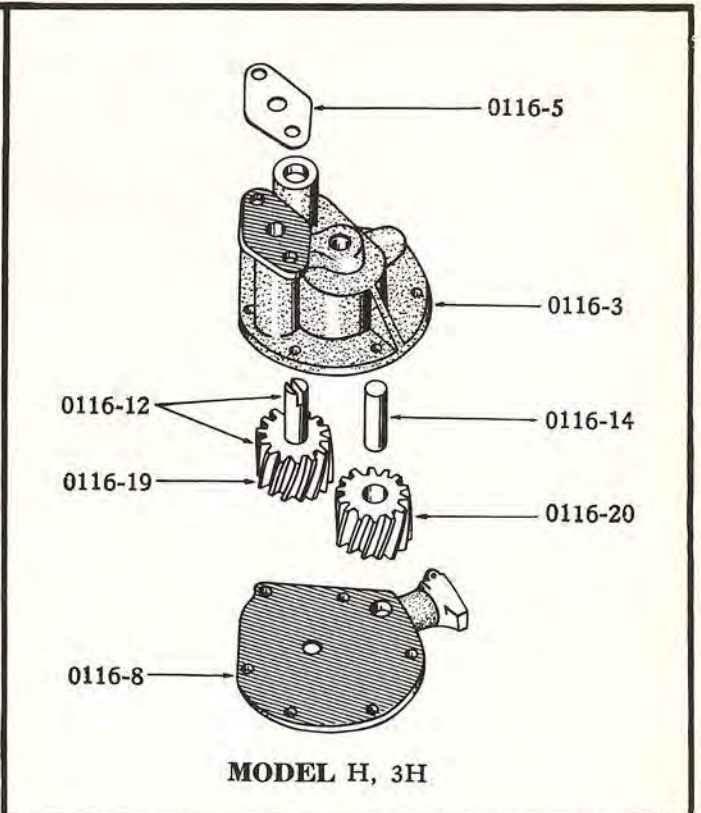
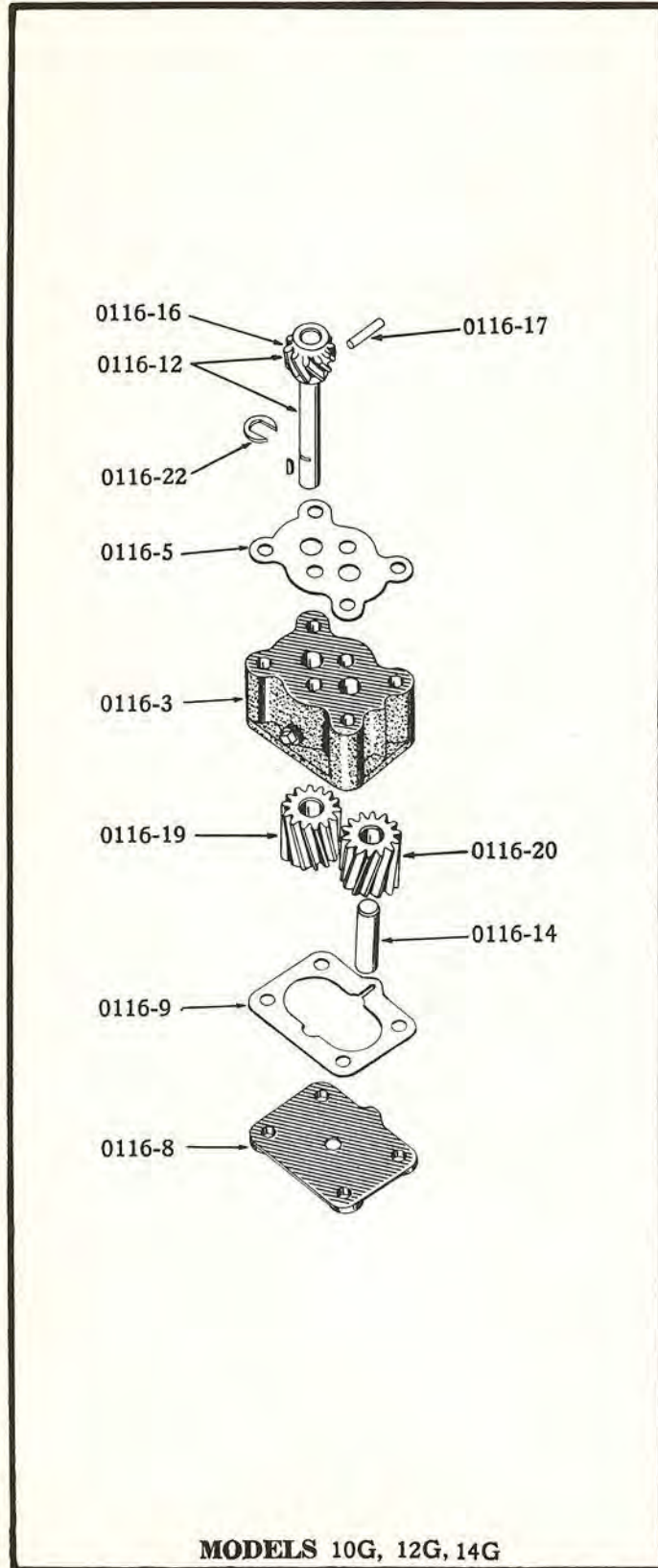

OIL PUMPS

0100

ENGINE

ILLUST. NUMBER	PART NUMBER	CHANGE	DESCRIPTION	MODELS	PER CAR
----------------	-------------	--------	-------------	--------	---------

0100- ENGINE ASSEMBLY

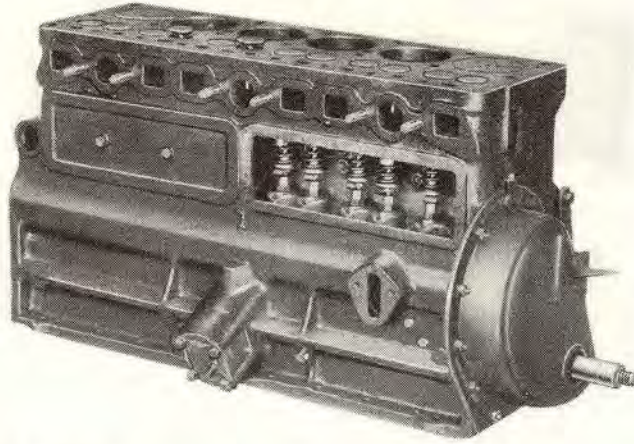

STRIPPED ENGINE:

CONSISTS OF CYLINDER BLOCK, PISTONS, RINGS, CONNECTING RODS, CRANKSHAFT, CAMSHAFT, ALL BEARINGS, TIMING GEARS AND COVER, OIL PRESSURE VALVE, OIL PAN FILLER BLOCK, ENGINE VALVES, VALVE SPRINGS, VALVE COVERS AND FLYWHEEL OR CONVERTOR BOLTS. COMMANDER ENGINES ALSO INCLUDE CYLINDER HEADS, VALVE MECHANISM AND VALVE LIFTER COVER. ENGINE No. 532912 ALSO INCLUDE OIL PUMP AND FRONT SUPPORT PLATE.

ENGINE Nos. 530848 AND 530861 ALSO INCLUDE OIL PUMP, OIL PAN, OIL STRAINER, VIBRATION DAMPER, CRANKSHAFT FAN PULLEY, DISTRIBUTOR SUPPORT AND ENGINE FRONT SUPPORT BRACKETS.

SHORT BLOCK:

CONSISTS OF CYLINDER BLOCK, PISTONS, RINGS, CONNECTING RODS, CRANKSHAFT, CAMSHAFT, ALL BEARINGS, TIMING GEARS AND COVER, OIL PRESSURE VALVE, OIL PAN FILLER BLOCK, VALVE LIFTER COVER AND FLYWHEEL OR CONVERTOR BOLTS. SHORT BLOCK NOS. 530847 AND 530860 ALSO INCLUDE OIL PUMP, OIL PAN, OIL STRAINER, VIBRATION DAMPER, CRANKSHAFT FAN PULLEY, DISTRIBUTOR SUPPORT AND ENGINE FRONT SUPPORT BRACKETS.

NOTE - ENGINES IDENTIFIED BY THE LETTER K STAMPED ON THE RIGHT END OF THE ENGINE SERIAL NUMBER PAD ARE EQUIPPED WITH CRANKSHAFT AND CONNECTING ROD BEARINGS .010 UNDER-SIZE.

532912	ENGINE STRIPPED.	10G.12G.14G	1
530848	ENGINE STRIPPED (EXCEPT AD TRANS.)	H, 3H.	1
530861	ENGINE STRIPPED (WITH AD TRANS.)	H, 3H.	1
532914	ENGINE STRIPPED.	4H.	1
530847	SHORT BLOCK, ENGINE (EXCEPT AD TRANS.)	H, 3H.	1
530860	SHORT BLOCK, ENGINE (WITH AD TRANS.)	H, 3H.	1
532913	SHORT BLOCK, ENGINE.	4H.	1

0101- ENGINE MOUNTINGS (Plates 01-1, 2, 3, 5)

FRONT MOUNTINGS

0101-1	527102	PLATE, ENGINE FRONT.	10G.12G.14G	1
	1-0512	SCREW, TO BLOCK 5/16"-18X3/4"	10G.12G.14G	5
	380-05	WASHER, LOCK 5/16"	10G.12G.14G	5
0101-2	194484	GASKET, ENGINE FRONT PLATE	10G.12G.14G	1

ENGINE

0101

ILLUST. NUMBER	PART NUMBER	CHANGE	DESCRIPTION	MODELS	PER CAR
----------------	-------------	--------	-------------	--------	---------

0101- ENGINE MOUNTINGS-Cont'd. (Plates 01-1, 2, 3, 5)

FRONT MOUNTINGS-Cont'd.

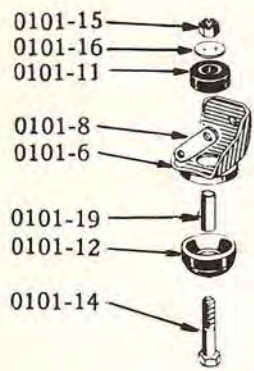

MODEL 10G, 12G

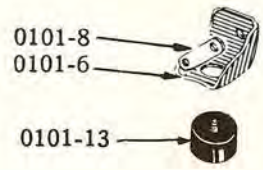

MODEL 14G

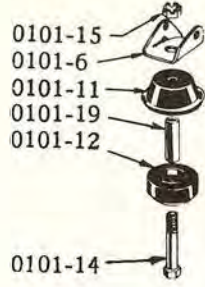

MODEL H, 3H

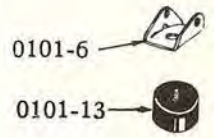

MODEL 4H

0101-6	530274	BRACKET, RIGHT, FRONT SUPPORT	} MOUNTED ON BLOCK	10G, 12G	1
	529415	BRACKET, LEFT, FRONT SUPPORT		10G, 12G	1
0101-6	532402	BRACKET, RIGHT, FRONT SUPPORT	} MOUNTED ON BLOCK	14G	1
	532403	BRACKET, LEFT, FRONT SUPPORT		14G	1
	203-0624	STUD, RIGHT, TO BLOCK 3/8"-16-24X1 1/2"		10G, 12G, 14G	2
	203-0628	STUD, LEFT, TO BLOCK 3/8"-16-24X1 3/4"		10G, 12G, 14G	2
	198007	NUT, HEX. 3/8"-24.		10G, 12G, 14G	4
	306-06	NUT, PAL. 3/8"		10G, 12G, 14G	4
0101-8	680180	REINFORCEMENT, BRACKET.		10G, 12G, 14G	2
0101-6	529342	BRACKET, FRONT SUPPORT	} MOUNTED ON BLOCK	H, 3H	2
0101-6	532404	BRACKET, FRONT SUPPORT		4H	2
	----	BOLT, TO BLOCK 3/8"-24X1 1/8"		H, 3H, 4H	5
	----	BOLT, TO BLOCK THRU GROUND STRAP 3/8"-24X1 1/4"		H, 3H, 4H	1
	252-06	NUT, HEX. 3/8"-24.		H, 3H, 4H	6
	367-06	WASHER, PLAIN 3/8"		H, 3H	1
	380-06	WASHER, LOCK 3/8"		H, 3H, 4H	6
0101-9	530212	BRACKET, RIGHT, FRONT SUPPORT	} MOUNTED ON FRAME CROSS MEMBER ILLUST. PLATES 15-1, 2	10G, 12G	1
	530213	BRACKET, LEFT, FRONT SUPPORT		10G, 12G	1
0101-9A	532398	BRACKET, RIGHT, FRONT SUPPORT - W-F-Y-D-N		14G	1
	532399	BRACKET, LEFT, FRONT SUPPORT - W-F-Y-D-N		14G	1
0101-9B	532378	BRACKET, RIGHT, FRONT SUPPORT - C-K		14G	1
	532379	BRACKET, LEFT, FRONT SUPPORT - C-K		14G	1
0101-9	530214	BRACKET, RIGHT, FRONT SUPPORT		H, 3H	1
	530215	BRACKET, LEFT, FRONT SUPPORT		H, 3H	1
0101-9A	532400	BRACKET, RIGHT, FRONT SUPPORT - W-F-Y-D-N		4H	1
	532401	BRACKET, LEFT, FRONT SUPPORT - W-F-Y-D-N		4H	1
0101-9B	532378	BRACKET, RIGHT, FRONT SUPPORT - C-K		4H	1
	532379	BRACKET, LEFT, FRONT SUPPORT - C-K		4H	1
	2-0612	BOLT, TO FRAME 3/8"-24X3/4.	10G, 12G, H, 3H	4	
	2-0612	BOLT, TO FRAME 3/8"-24X3/4 - W-F-Y-D-N.	14G, 4H	4	
	264-06	NUT, LOCK 3/8"-24.	10G, 12G, 14G, H, 3H, 4H	4	
	----	RIVET, TO FRAME (FLAT HEAD) 5/16"X7/8" - C-K.	14G, 4H	12	
0101-11	514711	INSULATOR, UPPER, FRONT SUPPORT.	10G, 12G	2	
0101-12	513104	INSULATOR, LOWER, FRONT SUPPORT.	10G, 12G	2	
0101-13	532331	INSULATOR, FRONT SUPPORT	14G	2	
0101-11	520987	INSULATOR, UPPER, FRONT SUPPORT.	H, 3H	2	
0101-12	530276	INSULATOR, LOWER, FRONT SUPPORT.	H, 3H	2	
0101-13	533296	INSULATOR, FRONT SUPPORT	4H	2	

0101

ENGINE

ILLUST. NUMBER	PART NUMBER	CHANGE	DESCRIPTION	MODELS	PER CAR
0101- ENGINE MOUNTINGS-Cont'd. (Plates 01-1, 2, 3, 5)					
FRONT MOUNTINGS-Cont'd.					
0101-14	12-0840		BOLT, TO FRAME 1/2"-20X2 1/2"	10G, 12G	2
0101-14	2-0844		BOLT, TO FRAME 1/2"-20X2 3/4"	H, 3H	2
0101-15	----		NUT, LOCK 1/2"-20	10G, 12G	2
0101-15	256-08		NUT, LOCK 1/2"-20	H, 3H	2
0101-16	675370		WASHER, SPACING 33/64"	10G, 12G, H, 3H	2
	----		WASHER, PLAIN 1/2"	H, 3H	2
	384-08		WASHER, LOCK 1/2"	H, 3H	2
	----		COTTER 3/32" X 1"	10G, 12G	2
	252-06		NUT, TO BRACKET 3/8"-24	14G, 4H	4
	----		WASHER, PLAIN 3/8"	14G, 4H	2
	380-06		WASHER, LOCK 3/8"	14G, 4H	4
0101-19	519917		SPACER, INSULATOR	10G, 12G	2
0101-19	194496		SPACER, INSULATOR	H, 3H	2

REAR MOUNTINGS

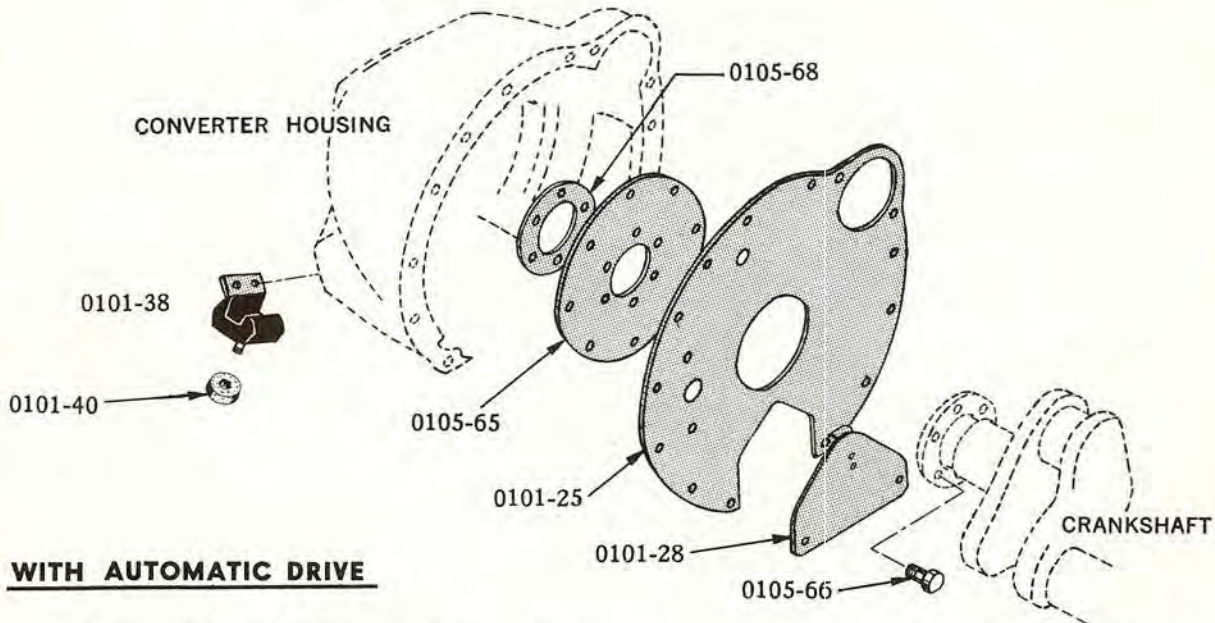

WITH AUTOMATIC DRIVE

0101-25	518457		PLATE, REAR SUPPORT (EXCEPT AD)	10G, 12G, 14G	1
0101-25	527563		PLATE, REAR SUPPORT (WITH AD) (ILLUST. ABOVE)	10G, 12G, 14G	1
0101-27	510165		DOWEL, PIN 3/8"X5/8"	10G, 12G, 14G	2
	1-0612		SCREW, TO BLOCK 3/8"-16X3/4"	10G, 12G, 14G	4
	384-06		WASHER, SHAKEPROOF 3/8"	10G, 12G, 14G	4
0101-28	527388		COVER W/CLIP, REAR SUPPORT PLATE (WITH AD) (ILLUST. ABOVE)	10G, 12G, 14G	1
	2-0416		BOLT, TO PLATE 1/4"-28X1"	10G, 12G, 14G	2
	252-04		NUT, HEX. 1/4"-28	10G, 12G, 14G	2
	----		WASHER, PLAIN 1/4"	10G, 12G, 14G	1
	----		WASHER, LOCK 1/4"	10G, 12G, 14G	2
0101-35	529338		INSULATOR, REAR SUPPORT (EXCEPT AD) NOTE 1	10G, 12G, H, 3H	1
0101-35	532258		INSULATOR, REAR SUPPORT (EXCEPT AD) NOTE 2	12G, 3H	1
0101-35	533330		INSULATOR, REAR SUPPORT (EXCEPT AD)	14G, 4H	1
	1-0836		SCREW, TO CLUTCH HOUSING 1/2"-13X2 1/4"	10G, 12G, H, 3H	2
	1-0840		SCREW, TO CLUTCH HOUSING 1/2"-13X2 1/2"	14G, 4H	2
	384-08		WASHER, SHAKEPROOF 1/2"	10G, 12G, H, 3H	2

- NOTES
- 1 - TYPE WITH 3 SECTION BASE USED ON MODELS 12G 3H
BEFORE ENGINE NOS. U.S.A. 943,464 V-165,403
CANADA C-40,565 VC-2,911
 - 2 - TYPE WITH CENTER SECTION OF BASE REMOVED USED ON AND AFTER ENGINE NOS. IN NOTE 1.

ENGINE

0102

ILLUST. NUMBER	PART NUMBER	CHANGE	DESCRIPTION	MODELS	PER CAR
0101- ENGINE MOUNTINGS-Cont'd. (Plates 01-1, 2, 3, 5)					
REAR MOUNTINGS-Cont'd.					
0101-38	526471		INSULATOR, REAR SUPPORT (WITH AD) (ILLUST. PAGE 10)	10G, 12G, H, 3H.	2
0101-38	526471		INSULATOR, RIGHT, REAR SUPPORT	14G, 4H.	1
0101-38	532425		INSULATOR, LEFT, REAR SUPPORT } WITH AD	14G, 4H.	1
	1-0712		SCREW, TO CONVERTOR HOUSING 7/16"-14X3/4"	10G, 12G, 14G, H, 3H, 4H	4
	380-07		WASHER, LOCK 7/16"	10G, 12G, 14G, H, 3H, 4H	4
	252-07		NUT, TO FRAME 7/16"-20	10G, 12G, 14G, H, 3H, 4H	2
	----		WASHER, PLAIN 7/16"	10G, 12G, 14G, H, 3H, 4H	2
	380-07		WASHER, LOCK 7/16"	10G, 12G, 14G, H, 3H, 4H	2
0101-40	532427		SPACER, LEFT SIDE.	14G, 4H.	1
0101-47	529269		CAGE, REAR SUPPORT INSULATOR (EXCEPT AD).	10G, 12G, H, 3H.	1
0101-47	532426		CAGE, REAR SUPPORT INSULATOR - LHC } WITH AD	14G, 4H.	1
0101-47	533201		CAGE, REAR SUPPORT INSULATOR - RHC }	14G, 4H.	1
	----		BOLT, TO CROSS MEMBER 3/8"-24X7/8"	10G, 12G, 14G, H, 3H, 4H	2
	252-06		NUT, HEX. 3/8"-24	10G, 12G, 14G, H, 3H, 4H	2
	380-06		WASHER, LOCK 3/8"	10G, 12G, 14G, H, 3H, 4H	2
	----		WASHER, PLAIN 3/8"	10G, 12G, H, 3H.	2
	----		WASHER, PLAIN 7/16"	14G	2
0102- CYLINDER BLOCK, HEAD AND GASKET					
(Plates 01-1, 2, 3, 5)					
CYLINDER BLOCK					
CYLINDER BLOCK: INCLUDES VALVE GUIDES (ON CHAMPION) CAM-SHAFT BEARINGS AND CRANKSHAFT MAIN BEARING CAPS. MAIN BEARINGS ARE NOT FURNISHED WITH CYLINDER BLOCK.					
	524830		CYLINDER BLOCK ASSEMBLY } FITTED WITH PISTONS.	10G, 12G, 14G	1
	530644		CYLINDER BLOCK ASSEMBLY } PINS AND RINGS	H, 3H, 4H	1
0102-1	524824		CYLINDER BLOCK.	10G, 12G, 14G	1
0102-3	172631		PLUG, WATER JACKET 1 1/2"	10G, 12G, 14G	1
	194166		PLUG, WATER JACKET 1 7/8"	10G, 12G, 14G	4
	547-06		PLUG, WATER JACKET DRAIN 3/8"	10G, 12G, 14G	1
	547-04		PLUG, OIL DISTRIBUTOR LINE END 1/4"	10G, 12G, 14G	4
	547-02		PLUG, CRANKSHAFT BEARING OIL HOLE 1/8"	10G, 12G, 14G	3
	549-02		PLUG, CRANKSHAFT BEARING OIL HOLE 1/8"	10G, 12G, 14G	1
	194665		PLUG, CAMSHAFT REAR BEARING 1 3/4"	10G, 12G, 14G	1
	106028		PLUG, OIL FILLER HOLE	10G, 12G, 14G	1
0102-1	529464		CYLINDER BLOCK.	H, 3H, 4H	1
	172631		PLUG, WATER JACKET 1 1/2"	H, 3H, 4H	6
	547-06		PLUG, WATER JACKET DRAIN 3/8"	H, 3H, 4H	2
	----		PLUG, OIL DISTRIBUTOR LINE END 3/8"	H, 3H, 4H	4
	530160		PLUG, OIL DISTRIBUTOR LINE END 1 1/4"	H, 3H, 4H	1
	172631		PLUG, CAMSHAFT REAR BEARING 1 1/2"	H, 3H, 4H	1
	547-02		PLUG, CAMSHAFT REAR BEARING OIL LINE 1/8"	H, 3H, 4H	1
	547-02		PLUG, DISTRIBUTOR DRIVE SHAFT OIL LINE 1/8" (SQUARE HEAD)	H, 3H, 4H	1
	----		PLUG, DISTRIBUTOR DRIVE SHAFT OIL LINE 1/8" (SLOTTED HEAD)	H, 3H, 4H	1
	527358		DRAIN COCK, CYLINDER BLOCK } SERVICE ONLY	10G, 12G, 14G	1
	680171		DRAIN COCK, CYLINDER BLOCK }	H, 3H, 4H	2
	----		BUSHING, REDUCING.	H, 3H, 4H	2
	1258XL8		HOSE, DRAIN COCK }	10G, 12G, 14G	1
	1258XM9		HOSE, DRAIN COCK }	H, 3H, 4H	1
0102-15	519859		TUBE, BREATHER.	10G, 12G, 14G	1
0102-15	530292		TUBE, BREATHER.	H, 3H, 4H	1
0103-24-2	196538		SCREW, THRU VALVE COVER 5/16"-18X4 7/16"	10G, 12G, 14G	1
0103-26-2	530320		SCREW, THRU VALVE LIFTER COVER 5/16"-18X5 1/16"	H, 3H, 4H	1



0102

ENGINE

ILLUST. NUMBER	PART NUMBER	CHANGE	DESCRIPTION	MODELS	PER CAR
0102- CYLINDER BLOCK, HEAD AND GASKET-Cont'd.					
(Plates 01-1, 2, 3, 5)					
CYLINDER BLOCK-Cont'd.					
0102-16	530410		BRACKET, BREATHER TUBE.	H, 3H, 4H	1
0102-18	194194		GASKET, BREATHER TUBE - CORK (INCL. IN S-369 SET)	10G, 12G, 14G	1
0102-18	510550		GASKET, BREATHER TUBE - CORK (INCL. IN 530814 SET).	H, 3H, 4H	1
0102-20	186622		PACK, BREATHER TUBE FILTER - BEFORE } ENGINE	10G	1
0102-20	530471		PACK, BREATHER TUBE FILTER - AFTER } No. 821,994	10G, 12G, 14G, H, 3H, 4H	1
	----		COTTER, 1/8"X1 1/2".	10G, 12G, 14G, H, 3H, 4H	1
CYLINDER HEAD					
0102-25	529278		HEAD, CYLINDER - STANDARD	10G, 12G	1
0102-25	529279		HEAD, CYLINDER - HIGH COMP. (FOR ALTITUDES OVER 5000 FT.)	10G, 12G	1
0102-25	529278		HEAD, CYLINDER - STANDARD	14G	1
0102-25	529279		HEAD, CYLINDER - HIGH COMP. } EXCEPT AD (FOR ALTITUDES OVER 5000 FT.)	14G	1
0102-25	529279		HEAD, CYLINDER (WITH AD).	14G	1
0102-26	547-06		PLUG, CORE 3/8" PIPE	10G, 12G, 14G	1
0102-28-1	194459		SCREW, TO BLOCK 7/16"-14X2 5/16" (LESS POWER STEERING)	10G, 12G, 14G	19
0102-28-1	194459		SCREW, TO BLOCK 7/16"-14X2 5/16" (WITH POWER STEERING)	14G	17
0102-28-2	519141		SCREW, TO BLOCK AND GROUND CABLE 7/16"-14X5/16"-18X3 17/64".	10G	1
	520498		SCREW, TO BLOCK THRU CABLES BRACKET 7/16"-14X2 11/16	10G, 12G, 14G	1
	533720		STUD, TO BLOCK 7/16"-14-20X3 9/16" (WITH POWER STEERING)	14G	2
0102-25	527222		HEAD, CYLINDER - STANDARD	H, 3H, 4H	2
0102-25	531375		HEAD, CYLINDER - HIGH COMP. (FOR ALTITUDES OVER 5000 FT.)	H, 3H, 4H	2
0102-26	551-12		PLUG, CORE 3/4" PIPE	H, 3H, 4H	4
	547-02		PLUG, OIL LINE 1/8" PIPE	H, 3H, 4H	2
0102-26-1	527831		DOWEL, PIN .434X21/32"	H, 3H, 4H	4
	527834		SCREW, TO BLOCK 7/16"-14X3 9/16" (LESS POWER STEERING)	H, 3H, 4H	18
	527834		SCREW, TO BLOCK 7/16"-14X3 9/16" (WITH POWER STEERING)	4H	16
	527835		SCREW, TO BLOCK 7/16"-14X4 1/4".	H, 3H, 4H	10
0103-59	527718		SCREW, TO BLOCK THRU ROCKER ARM BRACKET 7/16"-14X6 9/16"	H, 3H, 4H	8
	532446		STUD, TO BLOCK 7/16"-14-20X4 15/16" (WITH POWER STEER.).	4H	2
	361-07		WASHER, PLAIN 7/16" (FOR 527718).	H, 3H, 4H	8
0102-30	527058		GASKET, CYLINDER HEAD (INCL. IN S-369 SET).	10G, 12G, 14G	1
0102-30	529321		GASKET, CYLINDER HEAD (INCL. IN 530814 SET)	H, 3H, 4H	2
S-369			GASKET SET, VALVE GRINDING - CONSISTS OF THE FOLLOWING GASKETS:	10G, 12G, 14G	1
	1-527058	CYL. HEAD	1-194660 WATER OUTLET		
	2-196276	VALVE COVER	1-194658 THERMOSTAT		
	4-495-05	VALVE COVER	1-194194 BREATHER TUBE		
		SCREW			
530814			GASKET SET, VALVE GRINDING - CONSISTS OF THE FOLLOWING GASKETS AND OIL SEALS	H, 3H, 4H	1
	2-529321	CYL. HEAD	1-530263 MANIFOLD HEATER VALVE		
	2-531414	ROCKER ARM COVER	2-527240 WATER MANIFOLD- UPPER		
	2-530266	INLET MANIFOLD	2-527856 WATER MANIFOLD- LOWER		
	4-530264	EXH. MANIFOLD-END	1-510550 BREATHER TUBE		
	2-530265	EXH. MANIFOLD-CENTER	1-527284 WATER OUTLET		
	2-530263	EXH. PIPE FLANGE	16-527191 VALVE STEM OIL SEAL		
527304			COVER, RIGHT CYLINDER HEAD REAR END	H, 3H, 4H	1
----			SCREW, TO HEAD 5/16"-18X5/8"	H, 3H, 4H	2
380-05			WASHER, LOCK 5/16".	H, 3H, 4H	2
527240			GASKET, RIGHT CYLINDER HEAD REAR END COVER.	H, 3H, 4H	1

ENGINE

0103

ILLUST. NUMBER	PART NUMBER	CHANGE	DESCRIPTION	MODELS	PER CAR
0102- CYLINDER BLOCK, HEAD AND GASKET-Cont'd.					
(Plates 01-1, 2, 3, 5)					
CYLINDER HEAD-Cont'd.					
	----		RADIMETER OR HEAT INDICATOR (DASH UNIT)-SEE GROUP 1714 . . .		
0102-33	530127		GAGE, WATER TEMPERATURE (ENGINE UNIT)	10G, 12G, H, 3H	1
0102-33	532579		GAGE, WATER TEMPERATURE (ENGINE UNIT)	14G, 4H	1
	280-#10		NUT, TERMINAL No. 10-32	10G, 12G, 14G, H, 3H, 4H	1
	----		WASHER, LOCK No. 10	10G, 12G, 14G, H, 3H, 4H	1
0102-34	529456		ADAPTER, WATER TEMPERATURE GAGE	H, 3H, 4H	1
	----		SCREW, TO HEAD 5/16"-18X5/8"	H, 3H, 4H	2
	380-05		WASHER, LOCK 5/16"	H, 3H, 4H	2
	527240		GASKET, WATER TEMPERATURE GAGE ADAPTER	H, 3H, 4H	1
	531089		TERMINAL, WATER TEMPERATURE GAGE CABLE } AFTER CAR SERIALS	H, 3H, 4H	1
	531090		HOUSING, TERMINAL } 8.113.090 S.B. 8.801.064 L.A.	H, 3H, 4H	1
 0102-36 A  0102-36 B					
0102-36	199278		OUTLET, ENGINE WATER	10G, 12G	1
0102-36	532115		OUTLET, ENGINE WATER	14G	1
0102-36A	529412		OUTLET, ENGINE WATER	H, 3H	1
0102-36B	532383		OUTLET, ENGINE WATER	4H	1
0102-37	527835		SCREW, THRU HEAD 7/16"-14X4 1/8"	10G, 12G, 14G	2
	----		SCREW, TO WATER MANIFOLD 5/16"-18X7/8"	H, 3H, 4H	4
	380-05		WASHER, LOCK 5/16"	H, 3H, 4H	4
0102-38	194660		GASKET, ENGINE WATER OUTLET (INCL. IN S-369 SET)	10G, 12G, 14G	1
0102-38	527284		GASKET, ENGINE WATER OUTLET (INCL. IN 530814 SET)	H, 3H, 4H	1
THERMOSTAT-See Group 0504					
SPARK PLUGS-See Group 0603					
0103- ENGINE VALVES AND VALVE MECHANISM					
(Plates 01-3, 4, 5, 6)					
VALVES, SPRINGS, GUIDES, TAPPETS AND COVERS					
0103-1	194216		VALVE, INLET	10G, 12G, 14G	6
0103-2	194217		VALVE, OUTLET	10G, 12G, 14G	6
0103-1	527694		VALVE, INLET	H, 3H, 4H	8
0103-2	527693		VALVE, OUTLET	H, 3H, 4H	8
0103-4	194359		GUIDE, VALVE	10G, 12G, 14G	12
0103-4-1	527088		GUIDE, INLET VALVE	H, 3H, 4H	8
0103-4-2	530222		GUIDE, EXHAUST VALVE	H, 3H, 4H	8
0103-6	514236		SPRING, VALVE	10G, 12G, 14G	12
0103-6	533245		SPRING, VALVE	H, 3H, 4H	16
0103-8	168535		DAMPER, VALVE SPRING	H, 3H, 4H	16
0103-10	514235		RETAINER, VALVE SPRING	10G, 12G, 14G	12
0103-10-1	527767		RETAINER, INLET VALVE SPRING	H, 3H, 4H	8
0103-10-2	527766		RETAINER, EXHAUST VALVE SPRING	H, 3H, 4H	8
0103-12	195286		SEAT, VALVE SPRING	10G, 12G, 14G	12
0103-12	527180		SEAT, VALVE SPRING (ORDER BY PAIRS)	H, 3H, 4H	12

0103

ENGINE

ILLUST. NUMBER	PART NUMBER	CHANGE	DESCRIPTION	MODELS	PER CAR
0103- ENGINE VALVES AND VALVE MECHANISM-Cont'd.					
(Plates 01-3, 4, 5, 6)					
VALVES, SPRINGS, GUIDES, TAPPETS AND COVERS					
-Cont'd.					
0103-14	527191		OIL SEAL, VALVE STEM (INCL. IN 530814 SET)	H, 3H, 4H	16
0103-16	519077		TAPPET OR LIFTER W/SCREW, VALVE - STANDARD.	10G, 12G, 14G	12
0103-16	519079		TAPPET OR LIFTER W/SCREW, VALVE - .0005 OVERSIZE.	10G, 12G, 14G	12
0103-16	519080		TAPPET OR LIFTER W/SCREW, VALVE - .001 OVERSIZE	10G, 12G, 14G	12
0103-17	519078		SCREW, ADJUSTING 3/8"-24X3/4".	10G, 12G, 14G	12
0103-16	531696		TAPPET OR LIFTER, VALVE - STANDARD.	H, 3H, 4H	16
0103-16	531721		TAPPET OR LIFTER, VALVE - .0005 OVERSIZE.	H, 3H, 4H	16
0103-16	531722		TAPPET OR LIFTER, VALVE - .001 OVERSIZE	H, 3H, 4H	16
0103-20	195616		SPRING, VALVE LIFTER.	10G, 12G, 14G	12
0103-22-1	197486		COVER, FRONT, VALVE SPRING.	10G, 12G, 14G	1
0103-22-2	196689		COVER, REAR, VALVE SPRING	10G, 12G, 14G	1
0103-24-1	196539		SCREW, TO BLOCK 5/16"-18X3 1/8".	10G, 12G, 14G	3
0103-24-2	196538		SCREW, TO BLOCK 5/16"-18X4 7/16"	10G, 12G, 14G	1
	156768		GASKET, SCREW (INCL. IN S-369 SET).	10G, 12G, 14G	4
0103-25	196276		GASKET, VALVE SPRING COVER - CORK (INCL. IN S-369 SET).	10G, 12G, 14G	2
0103-26	527138		COVER, VALVE LIFTER	H, 3H, 4H	1
0103-26-2	527196		SCREW, TO BLOCK 5/16"-18X3 5/8".	H, 3H, 4H	2
	530220		SCREW, TO BLOCK 5/16"-18X5 1/16"	H, 3H, 4H	1
	156768		GASKET, SCREW	H, 3H, 4H	3
0103-26-3	527136		GASKET, VALVE LIFTER COVER.	H, 3H, 4H	1
0103-27	525265		BAFFLE, VALVE CHAMBER OIL	10G, 12G, 14G	1
ROCKER ARMS, SHAFT AND PUSH RODS					
0103-40	529432		ARM W/SCREW, VALVE ROCKER - NOTE 3.	H, 3H.	16
0103-40	532177		ARM W/SCREW, ENGINE VALVE ROCKER - NOTE 4	3H, 4H	16
0103-41	529400		SCREW, ADJUSTING 3/8"-24X3/4".-NOTE 3	H, 3H.	16
0103-41	532161		SCREW, ADJUSTING 3/8"-24X15/16" - NOTE 4	3H, 4H	16
0103-45	527199		SPRING, VALVE ROCKER ARM.	H, 3H, 4H	6
0103-46	527198		WASHER, SPRING	H, 3H, 4H	4
0103-47	527197		WASHER, INNER, PLAIN 53/64" I.D. X 1 5/16" O.D.	H, 3H, 4H	4
0103-47	531068		WASHER, OUTER, SPECIAL	H, 3H, 4H	4
	-----		COTTER, 3/32"X1 1/4".	H, 3H, 4H	4
0103-50	527890		PUSH ROD, VALVE ROCKER ARM.	H, 3H, 4H	16
0103-54	527182		SHAFT W/PLUGS, VALVE ROCKER ARM	H, 3H, 4H	2
0103-55	527184		PLUG, CUP 1/2"	H, 3H, 4H	4
0103-58	527696		BRACKET, VALVE ROCKER ARM SHAFT	H, 3H, 4H	8
0103-59	527718		SCREW, THRU CYL. HEAD 7/16"-14X6 9/16"	H, 3H, 4H	8
0103-60	527711		STUD, BRKT. AND ROCKER ARM COVER 5/16"-18-24X4 1/4".	H, 3H, 4H	8
	380-05		WASHER, STUD LOCK 5/16"	H, 3H, 4H	8
	530858		GROMMET, RUBBER	H, 3H, 4H	8
0103-63	531475		COVER, VALVE ROCKER ARM (INCL. RETAINERS).	H, 3H, 4H	2
0103-60	527711		STUD, THRU ROCKER ARM SHAFT BRKT. 5/16"-18-24X4 1/4"	H, 3H, 4H	8
	530851		NUT, CROWN 5/16"-24	H, 3H, 4H	8
	367-05		WASHER, PLAIN 11/32".	H, 3H, 4H	4

- NOTES {
- 3 - TYPE WITH 3/4" LONG ADJ. SCREW USED ON MODEL 3H BEFORE ENGINE NOS. U.S.A. V-155643 - CANADA VC-2676.
 - 4 - TYPE WITH 15/16" LONG ADJ. SCREW USED ON AND AFTER ENGINE NOS. IN NOTE 3.

ENGINE

0104

ILLUST. NUMBER	PART NUMBER	CHANGE	DESCRIPTION	MODELS	PER CAR
0103- ENGINE VALVES AND VALVE MECHANISM-Cont'd.					
(Plates 01-3, 4, 5, 6)					
ROCKER ARMS, SHAFT AND PUSH RODS-Cont'd.					
0103-65	527845	✓	GASKET, VALVE ROCKER ARM COVER - BEFORE	ENGINE No. U.S.A. V-60,197 CANADA VC-1,239	H 2
0103-65	531414		GASKET, VALVE ROCKER ARM COVER - AFTER		H, 3H, 4H 2
	531548		CLIP, GASKET RETAINER-SERVICE ONLY (FOR 527845)		H 20
0104- CAMSHAFT AND BEARINGS, GEAR AND COVER					
(Plates 01-3, 4, 5, 6)					
CAMSHAFT AND BEARINGS					
0104-1	524882		CAMSHAFT	10G, 12G, 14G	1
0104-1	532310		CAMSHAFT KIT (INCL. ROCKER ARM ADJ. SCREWS) NOTE 5	H, 3H	1
0104-1	532308		CAMSHAFT - NOTE 6	3H, 4H	1
0104-3	526224		BEARING SET, CAMSHAFT - CONSISTS OF:	10G, 12G, 14G	1
			1-196971 BEARING, FRONT 1-196973 BEARING, NO. 3		
			1-196972 BEARING, NO. 2 1-196974 BEARING, REAR		
0104-3	529459		BEARING SET, CAMSHAFT - CONSISTS OF:	H, 3H, 4H	1
			1-529460 BEARING, FRONT 1-529462 BEARING, NO. 3		
			1-529461 BEARING, NO. 2 1-529463 BEARING, NO. 4		
			1-530022 BEARING, REAR		
TIMING GEAR AND COVER					
0104-10	532125		GEAR, CAMSHAFT TIMING - STANDARD LIMIT.	10G, 12G, 14G	*
0104-10	532126		GEAR, CAMSHAFT TIMING - HIGH LIMIT.	10G, 12G, 14G	*
0104-10	532129		GEAR, CAMSHAFT TIMING - STANDARD LIMIT.	H, 3H, 4H	*
0104-10	532130		GEAR, CAMSHAFT TIMING - HIGH LIMIT.	H, 3H, 4H	*
	461-606		KEY, WOODRUFF 3/16"X3/4"	10G, 12G, 14G, H, 3H, 4H	1
0104-11	2-0616		SCREW, TO CAMSHAFT 3/8"-24X1"	10G, 12G, 14G, H, 3H, 4H	1
0104-12	----		WASHER, PLAIN 3/8"	10G, 12G, 14G, H, 3H, 4H	1
	380-06		WASHER, LOCK 3/8"	10G, 12G, 14G, H, 3H, 4H	1
0104-14	195385		SPACER, CAMSHAFT TIMING GEAR.	10G, 12G, 14G, H, 3H, 4H	1
0104-16	194228		THRUST PLATE, TIMING GEAR	10G, 12G, 14G	1
0104-16	527085		THRUST PLATE, TIMING GEAR	H, 3H, 4H	1
	512709		SCREW, TO BLOCK 5/16"-18X3/4"	10G, 12G, 14G	2
	527857		SCREW, TO BLOCK 5/16"-18X11/16"	H, 3H, 4H	2
	40X125		WASHER, LOCK 5/16"	10G, 12G, 14G, H, 3H, 4H	2
0104-20	518495		COVER, TIMING GEAR.	10G, 12G, 14G	1
	1-0512		SCREW, TO BLOCK 5/16"-18X3/4"	10G, 12G, 14G	8
	380-05		WASHER, LOCK 5/16"	10G, 12G, 14G	6
	156768		GASKET, SCREW	10G, 12G, 14G	2
	2-0512		BOLT, TO PLATE 5/16"-24X3/4"	10G, 12G, 14G	4
	252-05		NUT, HEX. 5/16"-24	10G, 12G, 14G	4
	361-05		WASHER, PLAIN 5/16"	10G, 12G, 14G	1
	380-05		WASHER, LOCK 5/16"	10G, 12G, 14G	4
0104-20	527121		COVER, TIMING GEAR.	H, 3H, 4H	1
	530312		SCREW AND WASHER, TO BLOCK 5/16"-18X5/8"	H, 3H, 4H	13
0104-22	194219		GASKET, TIMING GEAR COVER - CORK	10G, 12G, 14G	1
0104-22	527131		GASKET, TIMING GEAR COVER - CORK	H, 3H, 4H	1
0104-24	197591		WASHER, TIMING GEAR COVER - FELT	10G, 12G, 14G	1
0104-24	167156		WASHER, TIMING GEAR COVER - FELT	H, 3H, 4H	1
0104-26	675125		REINFORCEMENT, TIMING GEAR COVER.	10G, 12G, 14G	1

NOTES { * - USE AS REQUIRED.
 5 - USED ON MODEL 3H BEFORE ENGINE No. V-203,692.
 6 - TYPE WITH PRICK PUNCH MARKING ON FRONT END OF CAMSHAFT USED ON AND AFTER ENGINE No. IN NOTE 5.

0105

ENGINE

ILLUST. NUMBER	PART NUMBER	CHANGE	DESCRIPTION	MODELS	PER CAR
0105- CRANKSHAFT, BEARINGS, CAPS, GEAR AND DAMPER					
(Plates 01-4, 6)					
CRANKSHAFT					
0105-1	527779		CRANKSHAFT	10G, 12G, 14G	1
0105-1	530081		CRANKSHAFT (INCL. PILOT BEARING)	H, 3H, 4H	1
0105-3	194324		GEAR, CRANKSHAFT TIMING.	10G, 12G, 14G	1
0105-3	527084		GEAR, CRANKSHAFT TIMING.	H, 3H, 4H	1
	461-808		KEY, WOODRUFF 1/4"X1"	10G, 12G, 14G, H, 3H, 4H	1
0105-5	194077		THRUST WASHER, CRANKSHAFT.	10G, 12G, 14G	1
0105-5	527086		THRUST WASHER, CRANKSHAFT.	H, 3H, 4H	1
			THICK		
0105-7	194078		SHIM, CRANKSHAFT THRUST WASHER003.	10G, 12G, 14G	*
0105-7	197391		SHIM, CRANKSHAFT THRUST WASHER005.	10G, 12G, 14G	*
0105-7	197392		SHIM, CRANKSHAFT THRUST WASHER007.	10G, 12G, 14G	*
0105-7	186693		SHIM, CRANKSHAFT THRUST WASHER003.	H, 3H, 4H	*
0105-7	186694		SHIM, CRANKSHAFT THRUST WASHER005.	H, 3H, 4H	*
0105-7	186695		SHIM, CRANKSHAFT THRUST WASHER007.	H, 3H, 4H	*
0105-9	197592		SLINGER, CRANKSHAFT OIL.	10G, 12G, 14G	1
0105-9	189316		SLINGER, CRANKSHAFT OIL.	H, 3H, 4H	1
BEARING, clutch pilot - See Group 0207					
BEARING CAPS AND BEARINGS					
0105-15	195155		CAP, FRONT, CRANKSHAFT BEARING (No. 1)	10G, 12G, 14G	1
0105-16, 17	195156		CAP, INTERMEDIATE, CRANKSHAFT BEARING (No. 2, 3)	10G, 12G, 14G	2
0105-22	525648		CAP, REAR, CRANKSHAFT BEARING (No. 4)	10G, 12G, 14G	1
0105-23	186664		SCREW, TO BLOCK 1/2"-13X2 5/8".	10G, 12G, 14G	8
	167772		WASHER, PLAIN 33/64"	10G, 12G, 14G	8
0105-15	527066		CAP, FRONT, CRANKSHAFT BEARING (No. 1)	H, 3H, 4H	1
0105-16, 17, 18	527067		CAP, INTERMEDIATE, CRANKSHAFT BEARING (No. 2, 3, 4)	H, 3H, 4H	3
0105-22	527233		CAP, REAR, CRANKSHAFT BEARING (No. 5) (INCL. STUDS)	H, 3H, 4H	1
0105-23	181331		SCREW, TO BLOCK 1/2"-13X2 13/16".	H, 3H, 4H	10
	167772		WASHER, PLAIN 33/64"	H, 3H, 4H	10
0105-25	197178		OIL SEAL, REAR BEARING CAP - WOOD.	10G, 12G, 14G	2
0105-25	530526		OIL SEAL, RIGHT, REAR BEARING CAP - CORK	H, 3H, 4H	1
	530527		OIL SEAL, LEFT, REAR BEARING CAP - CORK.	H, 3H, 4H	1
0105-27	522144		SEAL, REAR BEARING CAP - RUBBER.	10G, 12G, 14G	2
0105-27	527249		SEAL, REAR BEARING CAP - RUBBER.	H, 3H, 4H	2
0105-30, 31, 32, 37	517900		BEARING SET, CRANKSHAFT - STANDARD - CONSISTS OF:	10G, 12G, 14G	1
			1-513404 BEARING, FRONT 1-519284 BEARING, REAR		
			2-513405 BEARING, (No. 2, 3)		
0105-30, 31, 32, 37	520827		BEARING SET, CRANKSHAFT - .001 UNDERSIZE - CONSISTS OF:	10G, 12G, 14G	1
			1-519282 BEARING, FRONT 1-519285 BEARING, REAR		
			2-519283 BEARING, No. 2, 3		
0105-30, 31, 32, 37	517901		BEARING SET, CRANKSHAFT - .010 UNDERSIZE - CONSISTS OF:	10G, 12G, 14G	1
			1-196997 BEARING, FRONT 1-519286 BEARING, REAR		
			2-512799 BEARING, No. 2, 3		
0105-30, 31, 32, 37	517902		BEARING SET, CRANKSHAFT - .020 UNDERSIZE - CONSISTS OF:	10G, 12G, 14G	1
			1-196998 BEARING, FRONT 1-519287 BEARING, REAR		
			2-512800 BEARING, No. 2, 3		
0105-30, 31, 32, 37	517903		BEARING SET, CRANKSHAFT - .030 UNDERSIZE - CONSISTS OF:	10G, 12G, 14G	1
			1-196999 BEARING, FRONT 1-519288 BEARING, REAR		
			2-512801 BEARING, No. 2, 3		

NOTE { * - USE AS REQUIRED.

ENGINE

0105

ILLUST. NUMBER	PART NUMBER	CHANGE	DESCRIPTION	MODELS	PER CAR
<p>0105- CRANKSHAFT, BEARINGS, CAPS, GEAR AND DAMPER -Cont'd. (Plates 01-4,6)</p> <p style="text-align: center;">BEARING CAPS AND BEARINGS-Cont'd.</p>					
0105-30, 31, 32, 33, 37	530796	✓	BEARING SET, CRANKSHAFT - STANDARD - CONSISTS OF: 1-530781 BEARING, FRONT 1-530791 BEARING, REAR 3-530786 BEARING, No. 2,3,4	H, 3H, 4H	1
0105-30, 31, 32, 33, 37	530797		BEARING SET, CRANKSHAFT - .001 UNDERSIZE - CONSISTS OF: 1-530782 BEARING, FRONT 1-530792 BEARING, REAR 3-530787 BEARING, No. 2,3,4	H, 3H, 4H	1
0105-30, 31, 32, 33, 37	530798		BEARING SET, CRANKSHAFT - .010 UNDERSIZE - CONSISTS OF: 1-530783 BEARING, FRONT 1-530793 BEARING, REAR 3-530788 BEARING, No. 2,3,4	H, 3H, 4H	1
0105-30, 31, 32, 33, 37	530799		BEARING SET, CRANKSHAFT - .020 UNDERSIZE - CONSISTS OF: 1-530784 BEARING, FRONT 1-530794 BEARING, REAR 3-530789 BEARING, No. 2,3,4	H, 3H, 4H	1
0105-30, 31, 32, 33, 37	530800		BEARING SET, CRANKSHAFT - .030 UNDERSIZE - CONSISTS OF: 1-530785 BEARING, FRONT 1-530795 BEARING, REAR 3-530790 BEARING, No. 2,3,4	H, 3H, 4H	1
<p>CRANKSHAFT BEARINGS SHOULD ALWAYS BE ORDERED IN SETS. THE SEPARATE BEARINGS WHICH COMPRISE THESE SETS MAY STILL BE OBTAINED AT THE FACTORY BUT SHOULD BE ORDERED ONLY WHEN A BEARING IN A SET HAS BEEN DAMAGED DURING INSTALLATION. SEE ABOVE LISTING OF BEARING SETS AND COMPONENT PARTS.</p>					
0105-40	531326		OIL SEAL, CRANKSHAFT REAR BEARING - RUBBER.	10G, 12G, 14G	2
0105-40	530311		OIL SEAL, CRANKSHAFT REAR BEARING - RUBBER.	H, 3H, 4H	2
VIBRATION DAMPER					
0105-45	519387		FLYWHEEL, VIBRATION DAMPER.	10G, 12G, 14G	1
0105-45	527830		FLYWHEEL, VIBRATION DAMPER.	H, 3H.	1
0105-45	533128		FLYWHEEL, VIBRATION DAMPER.	4H.	1
0105-46	515111		SCREW, TO CRANKSHAFT 11/16"-16X2 1/16"	10G, 12G, 14G, H, 3H.	1
0105-46	515111		SCREW, TO CRANKSHAFT 11/16"-16X2 1/16" (LESS POWER STEERING)	4H.	1
0105-46	534295		SCREW, TO CRANKSHAFT 11/16"-16X2 5/8" (WITH POWER STEERING)	4H.	1
0105-47	515202		LOCK PLATE.	10G, 12G, 14G, H, 3H, 4H	1
0105-48	522490		WASHER, PLAIN 11/16".	10G, 12G, 14G, H, 3H, 4H	1
0105-49	186703		CUSHION, FRONT, VIBRATION DAMPER - RUBBER	10G, 12G, 14G, H, 3H, 4H	1
0105-50	186704		CUSHION, REAR, VIBRATION DAMPER - RUBBER.	10G, 12G, 14G, H, 3H, 4H	1
0105-52	186702		PLATE, VIBRATION DAMPER LOCK.	10G, 12G, H, 3H, 4H	1
0105-52	186702		PLATE, VIBRATION DAMPER LOCK (LESS POWER STEERING).	14G	1
0105-52	533278		PLATE, VIBRATION DAMPER LOCK (WITH POWER STEERING).	14G	1
0105-54	516113		PILOT, VIBRATION DAMPER 1 3/16" LONG } LESS POWER.	10G, 12G, 14G	4
0105-54	182083		PILOT, VIBRATION DAMPER 1 13/32" LONG } STEERING	10G, 12G, 14G	2
0105-57	515926		PULLEY, FAN DRIVE (LESS POWER STEERING) (INCL. PILOTS).	10G, 12G, 14G	1
0105-57	534393		PULLEY, FAN DRIVE (WITH POWER STEERING)	14G	1
0105-57	527257		PULLEY, FAN DRIVE	H, 3H.	1
0105-57	533890		PULLEY, FAN DRIVE	4H.	1
	461-606		KEY, WOODRUFF 3/16"X3/4"	10G, 12G, 14G	1
	178762		BOLT, TO DAMPER 5/16"-24X1 3/8" (WITH POWER STEERING).	14G	6
	252-05		NUT, HEX. 5/16"-24.	14G	6
	380-05		WASHER, LOCK 5/16".	14G	6

0105

ENGINE

ILLUST. NUMBER	PART NUMBER	CHANGE	DESCRIPTION	MODELS	PER CAR
0105- CRANKSHAFT, BEARINGS, CAPS, GEAR AND DAMPER					
-Cont'd. (Plates 01-4, 6)					
VIBRATION DAMPER-Cont'd.					
0105-60	527252		HUB, FAN DRIVE PULLEY	H, 3H, 4H	1
	461-606		KEY, WOODRUFF 3/16"X3/4"	H, 3H, 4H	1
	178762		BOLT, TO PULLEY 5/16"-24X1 3/8" (LESS POWER STEERING)	H, 3H, 4H	6
	534350		BOLT, TO PULLEY 5/16"-24X2 1/8" (WITH POWER STEERING)	4H	6
	252-05		NUT, HEX. 5/16"-24	H, 3H, 4H	6
	380-05		WASHER, LOCK 5/16"	H, 3H, 4H	6
DRIVE PLATE (with AD) (Illustr. Page 10)					
0105-65	527800		PLATE, CRANKSHAFT TO CONVERTER DRIVE (WITH AD)	10G, 12G, 14G, H, 3H, 4H	1
0105-66	526851		BOLT, TO CRANKSHAFT 3/8"-24X15/16"	10G, 12G, 14G, H, 3H, 4H	6
	264-06		NUT, LOCK 3/8"-24	10G, 12G, 14G, H, 3H, 4H	6
0105-68	527801		REINFORCEMENT, CRANKSHAFT TO CONVERTER DRIVE PLATE (WITH AD)	10G, 12G, 14G, H, 3H, 4H	1
POWER STEERING DRIVE PULLEY (Plates 01-4, 6)					
0105-70	533891		PULLEY, POWER STEERING DRIVE	14G	1
0105-70	533890		PULLEY, POWER STEERING DRIVE	4H	1
0105-73	534294		SPACER, POWER STEERING DRIVE PULLEY	4H	1
0106- FLYWHEEL AND STARTER GEAR (Plates 01-4, 6)					
0106-1	525275		FLYWHEEL w/STARTER GEAR AND PILOT BEARING (EXCEPT AD)	10G, 12G, 14G	1
0106-1	527091		FLYWHEEL w/STARTER GEAR (EXCEPT AD)	H, 3H, 4H	1
0106-2	194542		BOLT, TO CRANKSHAFT 3/8"-24X1 13/16"	10G, 12G, 14G, H, 3H, 4H	6
	252-06		NUT, HEX. 3/8"-24	10G, 12G, 14G, H, 3H, 4H	6
	380-06		WASHER, LOCK 3/8"	10G, 12G, 14G, H, 3H, 4H	6
0106-6	525271		GEAR, STARTER RING (EXCEPT AD)	10G, 12G, 14G	1
0106-6	525272		GEAR, STARTER RING (EXCEPT AD)	H, 3H, 4H	1
----			HOUSING, CLUTCH AND FLYWHEEL - SEE GROUP 0209		
0107- CONNECTING RODS AND BEARINGS (Plates 01-4, 6)					
	520161		CONNECTING ROD SET - CONSISTS OF:	10G, 12G, 14G	1
			3-517921 CONN. ROD (No. 1, 3, 5) 3-517922 CONN. ROD (No. 2, 4, 6)		
	530759		CONNECTING ROD SET - CONSISTS OF:	H, 3H, 4H	1
			4-527114 CONN. ROD (No. 1, 3, 5, 7) 4-527115 CONN. ROD (No. 2, 4, 6, 8)		
0107-1	517921		CONNECTING ROD, LESS BEARINGS (No. 1, 3, 5)	10G, 12G, 14G	3
0107-1	517922		CONNECTING ROD, LESS BEARINGS (No. 2, 4, 6)	10G, 12G, 14G	3
0107-3	533801		BOLT, ROD CAP 11/32"-24X2 1/4"	10G, 12G, 14G	12
0107-4	196685		NUT, HEX. 11/32"-24	10G, 12G, 14G	12
0107-5	196710		NUT, PAL. 11/32"	10G, 12G, 14G	12
0107-7	197299		SCREW, TAPERED PISTON PIN LOCK 3/8"-24X1 11/16"	10G, 12G, 14G	6
	252-06		NUT, HEX. 3/8"-24	10G, 12G, 14G	6
	384-06		WASHER, SHAKEPROOF 3/8"	10G, 12G, 14G	6
0107-1	527114		CONNECTING ROD, LESS BEARINGS (No. 1, 3, 5, 7)	H, 3H, 4H	4
0107-1	527115		CONNECTING ROD, LESS BEARINGS (No. 2, 4, 6, 8)	H, 3H, 4H	4
0107-3	527089		BOLT, ROD CAP 3/8"-24X2 13/32"	H, 3H, 4H	16
0107-4	197402		NUT, HEX. 3/8"-24	H, 3H, 4H	16
0107-5	306-06		NUT, PAL. 3/8"	H, 3H, 4H	16
0107-7	529348		SCREW, TAPERED PISTON PIN LOCK 3/8"-24X1 27/32"	H, 3H, 4H	8
	252-06		NUT, HEX. 3/8"-24	H, 3H, 4H	8
	384-06		WASHER, SHAKEPROOF 3/8"	H, 3H, 4H	8

ENGINE

0108

ILLUST. NUMBER	PART NUMBER	CHANGE	DESCRIPTION	MODELS	PER CAR
0107- CONNECTING RODS AND BEARINGS-Cont'd. (Plates 01-4,6)					
0107-10	520834		BEARING UNIT, CONNECTING ROD - STANDARD	10G, 12G, 14G	6
0107-10	522292		BEARING UNIT, CONNECTING ROD - .001 UNDERSIZE	10G, 12G, 14G	6
0107-10	520835		BEARING UNIT, CONNECTING ROD - .005 UNDERSIZE	10G, 12G, 14G	6
0107-10	520836		BEARING UNIT, CONNECTING ROD - .010 UNDERSIZE	10G, 12G, 14G	6
0107-10	520837		BEARING UNIT, CONNECTING ROD - .020 UNDERSIZE	10G, 12G, 14G	6
0107-10	530761		BEARING UNIT, CONNECTING ROD - STANDARD	H, 3H, 4H	8
0107-10	530762		BEARING UNIT, CONNECTING ROD - .001 UNDERSIZE	H, 3H, 4H	8
0107-10	530763		BEARING UNIT, CONNECTING ROD - .005 UNDERSIZE	H, 3H, 4H	8
0107-10	530764		BEARING UNIT, CONNECTING ROD - .010 UNDERSIZE	H, 3H, 4H	8
0107-10	530765		BEARING UNIT, CONNECTING ROD - .020 UNDERSIZE	H, 3H, 4H	8
0108- PISTONS, PINS AND RINGS (Plates 01-4,6)					
0108-1	524316		PISTON w/PIN - STANDARD	10G, 12G, 14G	6
0108-1	524294		PISTON w/PIN - .010 OVERSIZE	10G, 12G, 14G	6
0108-1	524296		PISTON w/PIN - .020 OVERSIZE	10G, 12G, 14G	6
0108-1	524297		PISTON w/PIN - .030 OVERSIZE	10G, 12G, 14G	6
0108-1	522112		PISTON w/PIN - .040 OVERSIZE	10G, 12G, 14G	6
0108-1	529428		PISTON w/PIN - STANDARD	H, 3H, 4H	8
0108-1	530640		PISTON w/PIN - .010 OVERSIZE	H, 3H, 4H	8
0108-1	530641		PISTON w/PIN - .020 OVERSIZE	H, 3H, 4H	8
0108-1	530642		PISTON w/PIN - .030 OVERSIZE	H, 3H, 4H	8
0108-1	530643		PISTON w/PIN - .040 OVERSIZE	H, 3H, 4H	8
0108-3	195268		PISTON PIN - STANDARD	10G, 12G, 14G	6
0108-3	195873		PISTON PIN - .0025 OVERSIZE	10G, 12G, 14G	6
0108-3	195874		PISTON PIN - .005 OVERSIZE	10G, 12G, 14G	6
0108-3	521689		PISTON PIN - STANDARD	H, 3H, 4H	8
0108-3	521690		PISTON PIN - .0025 OVERSIZE	H, 3H, 4H	8
0108-3	521691		PISTON PIN - .005 OVERSIZE	H, 3H, 4H	8
PISTON RINGS					
0108-7, 8,9	518102	●	PISTON RING SET - STANDARD - CONSISTS OF: 6-196596 COMP. RING, TOP 6-520203 OIL RING AND INNER RING 6-196575 COMP. RING, 2ND	10G, 12G, 14G	1
0108-7, 8,9	518103	●	PISTON RING SET - .020 OVERSIZE - CONSISTS OF: 6-196614 COMP. RING, TOP 6-520204 OIL RING AND INNER RING 6-196617 COMP. RING, 2ND	10G, 12G, 14G	1
0108-7, 8,9	518104	●	PISTON RING SET - .030 OVERSIZE - CONSISTS OF: 6-196615 COMP. RING, TOP 6-520205 OIL RING AND INNER RING 6-196618 COMP. RING, 2ND	10G, 12G, 14G	1
0108-7, 8,9	522695	●	PISTON RING SET - .040 OVERSIZE - CONSISTS OF: 6-522115 COMP. RING, TOP 6-522448 OIL RING AND INNER RING 6-522116 COMP. RING, 2ND	10G, 12G, 14G	1
0108-7, 8,9	527033	■	PISTON RING SET - STANDARD - CONSISTS OF: 6-527028 COMP. RING, TOP 6-520203 OIL RING AND INNER RING 6-196575 COMP. RING, 2ND	10G, 12G, 14G	1
0108-7, 8,9	527035	■	PISTON RING SET - .020 OVERSIZE - CONSISTS OF: 6-527030 COMP. RING, TOP 6-520204 OIL RING AND INNER RING 6-196617 COMP. RING, 2ND	10G, 12G, 14G	1
0108-7, 8,9	527036	■	PISTON RING SET - .030 OVERSIZE - CONSISTS OF: 6-527031 COMP. RING, TOP 6-520205 OIL RING AND INNER RING 6-196618 COMP. RING, 2ND	10G, 12G, 14G	1
<p>● - TYPE WITH STANDARD TOP RING. ■ - TYPE WITH CHROME PLATED TOP RING.</p>					

0108

ENGINE

ILLUST. NUMBER	PART NUMBER	CHANGE	DESCRIPTION	MODELS	PER CAR
0108- PISTONS, PINS AND RINGS-Cont'd. (Plates 01-4, 6)					
PISTON RINGS-Cont'd.					
0108-7, 8,9	527037	■	PISTON RING SET - .040 OVERSIZE - CONSISTS OF: 6-527032 COMP. RING, TOP 6-522448 OIL RING AND INNER RING 6-522116 COMP. RING, 2ND RING	10G, 12G, 14G	1
0108-7, 8,9	530975	●	PISTON RING SET - STANDARD - CONSISTS OF: 16-527724 COMPRESSION RING 8-530986 OIL RING AND INNER RING	H, 3H, 4H	1
0108-7, 8,9	530976	●	PISTON RING SET - .020 OVERSIZE - CONSISTS OF: 16-530979 COMPRESSION RING 8-530987 OIL RING AND INNER RING	H, 3H, 4H	1
0108-7, 8,9	530977	●	PISTON RING SET - .030 OVERSIZE - CONSISTS OF: 16-530980 COMPRESSION RING 8-530988 OIL RING AND INNER RING	H, 3H, 4H	1
0108-7, 8,9	530978	●	PISTON RING SET - .040 OVERSIZE - CONSISTS OF: 16-530981 COMPRESSION RING 8-530989 OIL RING AND INNER RING	H, 3H, 4H	1
0108-7, 8,9	531664	■	PISTON RING SET - STANDARD - CONSISTS OF: 8-531660 COMP. RING, TOP 8-530986 OIL RING AND INNER RING 8-527724 COMP. RING, 2ND RING	H, 3H, 4H	1
0108-7, 8,9	531665	■	PISTON RING SET - .020 OVERSIZE - CONSISTS OF: 8-531661 COMP. RING, TOP 8-530987 OIL RING AND INNER RING 8-530979 COMP. RING, 2ND RING	H, 3H, 4H	1
0108-7, 8,9	531666	■	PISTON RING SET - .030 OVERSIZE - CONSISTS OF: 8-531662 COMP. RING, TOP 8-530988 OIL RING AND INNER RING 8-530980 COMP. RING, 2ND RING	H, 3H, 4H	1
0108-7, 8,9	531667	■	PISTON RING SET - .040 OVERSIZE - CONSISTS OF: 8-531663 COMP. RING, TOP 8-530989 OIL RING AND INNER RING 8-530981 COMP. RING, 2ND RING	H, 3H, 4H	1
<p>● - TYPE WITH STANDARD TOP RING. ■ - TYPE WITH CHROME PLATED TOP RING.</p>					
PISTON RINGS SHOULD ALWAYS BE ORDERED IN SETS. THE SEPARATE RINGS WHICH COMPRISE THESE SETS MAY STILL BE OBTAINED AT THE FACTORY BUT SHOULD BE ORDERED ONLY WHEN A RING IN A SET HAS BEEN DAMAGED OR BROKEN DURING INSTALLATION. SEE PAGES 19 AND 20 FOR RING SETS AND COMPONENT PARTS.					
0109- INLET AND EXHAUST MANIFOLDS AND HEAT CONTROL (Plates 01-3, 5, 7)					
0109-1	525666		MANIFOLD w/BUSHING, INLET AND EXHAUST (EXHAUST STOCK, THEN USE 533790)	10G, 12G	1
0109-1	533790		MANIFOLD w/BUSHING, INLET AND EXHAUST } INCL. HEATER TUBE	10G, 12G	1
0109-1	532734		MANIFOLD w/BUSHING, INLET AND EXHAUST }	14G	1
	549-02		PLUG, INLET MANIFOLD PIPE 1/8"	10G, 12G, 14G	1
0109-7	513113		PLUG, AUTO, CHOKE TUBE	10G, 12G	1
0109-9	520458		PLUG, HEATER VALVE SHAFT HOLE.	10G, 12G, 14G	1
	526447		STUD, END, TO BLOCK 3/8"-16-24X1 11/16".	10G, 12G, 14G	2
	203-0633		STUD, CENTER, TO BLOCK 3/8"-16-24X2 1/16".	10G, 12G, 14G	4
	203-0622		STUD, EXHAUST PIPE 3/8"-16-24X1 3/8"	10G, 12G, 14G	2
	254-06		NUT, HEX, 3/8"-24	10G, 12G, 14G	8
	41X243		WASHER, PLAIN 13/32".	10G, 12G, 14G	2
0109-11	196664		CLAMP, MANIFOLD TO BLOCK	10G, 12G, 14G	4

ENGINE

0109

ILLUST. NUMBER	PART NUMBER	CHANGE	DESCRIPTION	MODELS	PER CAR
0109- INLET AND EXHAUST MANIFOLDS AND HEAT CONTROL					
-Cont'd. (Plates 01-3,5,7)					
0109-2	527914		MANIFOLD w/PLUGS, INLET - NOTE 7.	H	1
0109-2	531389		MANIFOLD w/PLUGS, INLET - NOTE 8.	H, 3H.	1
0109-2	533137		MANIFOLD w/PLUGS, INLET	4H.	1
0109-4	529489		MANIFOLD, RIGHT, EXHAUST.	H, 3H, 4H	1
0109-5	529490		MANIFOLD, LEFT, EXHAUST	H, 3H.	1
0109-5	532424		MANIFOLD, LEFT, EXHAUST (LESS POWER STEERING)	4H.	1
0109-5	534414		MANIFOLD, LEFT, EXHAUST (WITH POWER STEERING)	4H.	1
	----		PLUG, INLET MANIFOLD 1".	H, 3H, 4H	2
	547-02		PLUG, INLET MANIFOLD 1/8".	H, 3H, 4H	1
	1-0664		SCREW, INLET MANIFOLD TO HEAD 3/8"-16X4"	H, 3H, 4H	4
	529491		SCREW, EXHAUST MANIFOLD TO HEAD 3/8"-16X1 3/16".	H, 3H, 4H	12
	----		WASHER, PLAIN 13/32" (FOR 1-0664)	H, 3H, 4H	4
	41X243		WASHER, PLAIN 13/32" (FOR 529491)	H, 3H, 4H	12
	284-06		WASHER, LOCK 3/8" (FOR 529491)	4H.	12
	203-0633		STUD, RIGHT, EXHAUST PIPE 3/8"-16-24X2 1/16"	H, 3H, 4H	2
	203-0624		STUD, LEFT, EXHAUST PIPE 3/8"-16-24X1 1/2"	H, 3H, 4H	2
	254-06		NUT, HEX. 3/8"-24	H, 3H, 4H	4
	41X243		WASHER, PLAIN 13/32".	H, 3H, 4H	4
0109-11	529349		CLAMP, INLET MANIFOLD.	H, 3H, 4H	4
	S-370		GASKET SET, MANIFOLD - CONSISTS OF:	10G, 12G, 14G	1
			1-196693 MANIFOLD GASKET 1-522070 CARBURETER GASKET		
			1-680291 EXHAUST PIPE GASKET GASKET		
	530815		GASKET SET, MANIFOLD - CONSISTS OF:	H, 3H, 4H	1
			2-530266 INLET MANIFOLD GASKET 2-530263 EXHAUST PIPE GASKET		
			4-530264 EXHAUST MANIFOLD GASKET-END 1-530263 HEATER VALVE GASKET		
			2-530265 EXHAUST MANIFOLD GASKET-CENTER		
			INCL. IN SET		
0109-18	196693		GASKET, MANIFOLD TO BLOCK S-370	10G, 12G, 14G	1
0109-19	530266		GASKET, INLET MANIFOLD. 530814 & 15	H, 3H, 4H	2
0109-21-1	530264		GASKET, END, EXHAUST MANIFOLD 530814 & 15	H, 3H, 4H	4
0109-21-2	530265		GASKET, CENTER, EXHAUST MANIFOLD. 530814 & 15	H, 3H, 4H	2
0109-22	680291		GASKET, EXHAUST PIPE FLANGE S-370	10G, 12G, 14G	1
0109-22	530263		GASKET, EXHAUST PIPE FLANGE 530814 & 15	H, 3H, 4H	2
0109-24	530369		COVER, EXHAUST MANIFOLD STOVE - NOTE 9.	H	1
0109-25-1	530370		CLAMP, FRONT, TO MANIFOLD.	H	2
0109-25-2	530371		CLAMP, REAR, TO MANIFOLD	H	2
	2-0410		BOLT, CLAMPING 1/4"-28X5/8"	H	4
	----		NUT, HEX. 1/4"-28	H	4
	530959		GASKET - CORBESTOS	H	1
MANIFOLD HEATER (Plate 01-7)					
0109-27	196655		VALVE AND SHAFT, MANIFOLD HEATER.	10G, 12G, 14G	1
0109-27A	527392		VALVE ASSY., HEATER - NOTE 10 } INCL. BALANCE, THERMOSTAT.	H, 3H.	1
0109-27B	533118		VALVE ASSY., HEATER - NOTE 11 } STOP CLIP AND PIN	3H, 4H	1
			(FASTENED WITH EXHAUST PIPE FLANGE STUDS		
0109-30	196658		SPACER, HEATER VALVE.	10G, 12G, 14G	1
0109-31	530263		GASKET, HEATER VALVE HOUSING (INCL. IN 530814 & 15 SETS)	H, 3H, 4H	1

- NOTES
- 7 - TYPE LESS HOLE FOR HEATER TUBE USED ON MODEL H BEFORE ENGINE NO. V-95,954.
 - 8 - TYPE WITH HOLE DRILLED FOR HEATER TUBE USED ON AND AFTER ENGINE NO. IN NOTE 7.
 - 9 - USED ON MODEL H BEFORE ENGINE NO. V-95,954.
 - 10 - TYPE WITH PLAIN BALANCE USED ON MODEL 3H BEFORE ENGINE NO. V-192685.
 - 11 - TYPE WITH HOODED BALANCE TO COVER THERMOSTAT USED ON AND AFTER ENGINE NO. IN NOTE 10.

ENGINE

0109

ILLUST. NUMBER	PART NUMBER	CHANGE	DESCRIPTION	MODELS	PER CAR
0109- INLET AND EXHAUST MANIFOLDS AND HEAT CONTROL					
-Cont'd. (Plates 01-3, 5, 7)					
MANIFOLD HEATER (Plate 01-7)-Cont'd.					
0109-32	515832		COVER w/BUSHING, HEATER VALVE	10G, 12G, 14G	1
	1-0512		SCREW, TO MANIFOLD 5/16"-18X3/4"	10G, 12G, 14G	2
	380-05		WASHER, LOCK 5/16"	10G, 12G, 14G	2
0109-33	196414		GASKET, HEATER VALVE COVER.	10G, 12G, 14G	1
0109-37	515821		BUSHING, HEATER VALVE SHAFT	10G, 12G, 14G	2
0109-43	196662		BALANCE, HEATER VALVE	10G, 12G, 14G	1
	----		BALANCE, HEATER VALVE (FURNISHED AS PART OF VALVE) NOTE 10.	H, 3H.	1
0109-43	533122		BALANCE, HEATER VALVE (FURNISHED AS PART OF VALVE) NOTE 11.	3H, 4H	1
0109-44	199006		SET SCREW 1/4"-20X9/16"	10G, 12G, 14G	1
	223-045		SET SCREW 1/4"-20X5/16" - NOTE 11.	3H, 4H	1
0109-46	196661		THERMOSTAT, HEATER VALVE.	10G, 12G, 14G	1
0109-46	530009		THERMOSTAT, HEATER VALVE.	H, 3H, 4H	1
0109-47	525801		PIN, STOP 5/16"X7/8" (PRESSED IN COVER).	10G, 12G, 14G	1
0115- OIL PAN, GASKETS, FILLER AND LEVEL GAGE					
(Plates 01-3, 5)					
0115-1	529264		OIL PAN w/PLUG.	10G, 12G	1
0115-1	531917		OIL PAN w/PLUG.	14G	1
0115-1	527145		OIL PAN w/PLUG.	H, 3H.	1
0115-1	527145		OIL PAN w/PLUG - W-F-Y-D-N.	4H.	1
0115-1	531849		OIL PAN w/PLUG - C-K.	4H.	1
0115-2	510080		PLUG, DRAIN 3/4"-16.	10G, 12G, 14G, H, 3H, 4H	1
0115-3	168011		GASKET, PLUG.	10G, 12G, 14G, H, 3H, 4H	1
	530312		SCREW AND WASHER, TO BLOCK 5/16"-18X5/8"	10G, 12G, 14G	18
	530312		SCREW AND WASHER, TO BLOCK 5/16"-18X5/8"	H, 3H, 4H	20
0115-6	519636		BLOCK, OIL PAN FILLER	10G, 12G, 14G	1
0115-6	527123		BLOCK, OIL PAN FILLER	H, 3H, 4H	1
0115-9	S-346		■ GASKET SET, OIL PAN	10G, 12G, 14G	1
0115-9	530813		■ GASKET SET, OIL PAN	H, 3H, 4H	1
			■ - CONSISTS OF 1 EACH OF THE FOLLOWING GASKETS: TOP RIGHT, TOP LEFT, FRONT AND REAR.		
0115-10	527146		GASKET, REAR, OIL PAN	4H.	1
0115-18	531000		CAP, OIL PAN FILLER	10G, 12G, 14G, H, 3H, 4H	1
0115-20	525922		TUBE, OIL PAN FILLER.	10G, 12G, 14G	1
0301-2-1	----		TUBE, OIL PAN FILLER (SEE FUEL PUMP SUPPORT - GROUP 0301) .	H, 3H, 4H	1
	547-02		PLUG, PIPE 1/8"	10G, 12G, 14G	1

NOTES

- 10 - TYPE WITH PLAIN BALANCE USED ON MODEL 3H BEFORE ENGINE NO. V-192,685.
- 11 - TYPE WITH HOODED BALANCE TO COVER THERMOSTAT USED ON AND AFTER ENGINE NO. IN NOTE 10.

ENGINE

0116

ILLUST. NUMBER	PART NUMBER	CHANGE	DESCRIPTION	MODELS	PER CAR
----------------	-------------	--------	-------------	--------	---------

0115- OIL PAN, GASKETS, FILLER AND LEVEL GAGE-Cont'd. (Plates 01-3, 5)

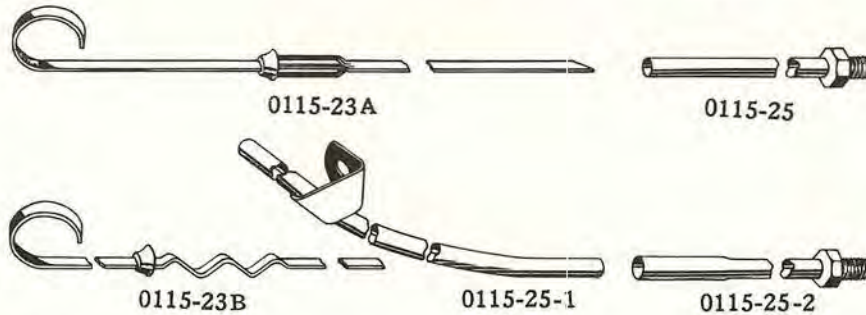

0115-23	526411		GAGE, OIL LEVEL	10G, 12G, 14G	1
0115-23A	▲530363		GAGE, OIL LEVEL - BEFORE } ENGINE (USE 1 EA. 530994 & 5)	H	1
0115-23B	530995		GAGE, OIL LEVEL - AFTER } No. V-336	H, 3H.	1
0115-23B	533209		GAGE, OIL LEVEL - W-F-Y-D-N	4H.	1
0115-23A	533185		GAGE, OIL LEVEL - C-K	4H.	1
0115-25	525895		TUBE, OIL LEVEL GAGE.	10G, 12G, 14G	1
0115-25	▲ 530139		TUBE, OIL LEVEL GAGE - BEFORE } ENGINE (USE 1 EA. 530994 & 5)	H	1
0115-25	530994		TUBE, OIL LEVEL GAGE - AFTER } No. V-336)	H, 3H.	1
0115-25-1	533221		TUBE AND BRACKET, UPPER, OIL LEVEL GAGE - W-F-Y-D-N	4H.	1
0115-25-2	533220		TUBE, LOWER, OIL LEVEL GAGE - W-F-Y-D-N	4H.	1
0115-25	530994		TUBE, OIL LEVEL GAGE - C-K.	4H.	1
0115-26	525898		RETAINER	10G, 12G, 14G	1
0115-28	525897		WASHER, OIL LEVEL GAGE TUBE - FELT.	10G, 12G, 14G	1
	495-07		WASHER, OIL LEVEL GAGE TUBE - COPPER.	H, 3H, 4H	1

ENGINE BREATHER TUBE - See Group 0102

0116- OIL PUMP, STRAINER AND PRESSURE GAGE PIPES (Plates 01-3, 5, 8)

OIL PUMP

0116-1	521999		PUMP KIT, OIL-CONSISTS OF:	10G, 12G, 14G	1
			---- BODY		
			1-525056 COVER	1-195406 SHAFT, IDLER	
			1-521371 GASKET, COVER	4-1-0544 SCREW, FAST.	
			1-518913 GEAR, DRIVE	4-380-05 WASHER, LOCK	
			1-461-404 KEY	1-519084 SHAFT AND GEAR, DRIVE	
			1-518914 GEAR, IDLER	1-194592 THRUST WASHER	
0116-1	529220		OIL PUMP, COMPLETE.	H, 3H.	1
0116-1	531850		OIL PUMP, COMPLETE.	4H.	1
	203-0522		STUD, TO REAR BRG. CAP 5/16"-18-24X1 3/8".	H, 3H, 4H	2
	252-05		NUT, HEX. 5/16"-24.	H, 3H, 4H.	2
	380-05		WASHER, LOCK 5/16".	H, 3H, 4H	2
0116-3	----		BODY, OIL PUMP (USE 521999 PUMP KIT).	10G, 12G, 14G	1
0116-3	----		BODY, OIL PUMP (USE 529220 OR 531850 PUMP).	H, 3H, 4H	1
	547-02		PLUG, PIPE 1/8".	10G, 12G, 14G	1
	1-0544		SCREW, TO BLOCK 5/16"-18X2 3/4".	10G, 12G, 14G	4
	380-05		WASHER, LOCK 5/16".	10G, 12G, 14G	4
0116-5	195304		GASKET, OIL PUMP BODY - PAPER	10G, 12G, 14G	1
0116-5	527224		GASKET, OIL PUMP BODY - PAPER	H, 3H, 4H	1

NOTE { ▲ - NOT AVAILABLE.

ENGINE

0116

ILLUST. NUMBER	PART NUMBER	CHANGE	DESCRIPTION	MODELS	PER CAR
0116- OIL PUMP, STRAINER AND PRESSURE GAGE PIPES					
-Cont'd. (Plates 01-3, 5, 8)					
OIL PUMP-Cont'd.					
0116-8	525056		COVER, OIL PUMP BODY	10G, 12G, 14G	1
0116-8	529213		COVER, OIL PUMP BODY	H, 3H.	1
0116-8	531853		COVER, OIL PUMP BODY	4H.	1
	----		SCREW, TO BODY 1/4"-20X5/8"	H, 3H, 4H	6
	380-04		WASHER, LOCK 1/4"	H, 3H, 4H	6
0116-9	521371		GASKET, OIL PUMP BODY COVER.	10G, 12G, 14G	1
0116-12	523822		SHAFT, OIL PUMP DRIVE (INCL. DRIVE GEAR)	10G, 12G, 14G	1
0116-12	527155		SHAFT, OIL PUMP DRIVE (INCL. DRIVEN GEAR).	H, 3H, 4H	1
0116-14	195406		SHAFT, OIL PUMP IDLER GEAR	10G, 12G, 14G	1
0116-14	527158		SHAFT, OIL PUMP IDLER GEAR	H, 3H, 4H	1
0116-16	199133		GEAR, OIL PUMP AND DISTRIBUTOR DRIVE	10G, 12G, 14G	1
0601-44	----		GEAR, OIL PUMP AND DISTRIBUTOR DRIVE (SEE GROUP 0601).	H, 3H, 4H	1
0116-17	156090		PIN, TO SHAFT 3/16"X27/32".	10G, 12G, 14G	1
0116-19	518913		GEAR, OIL PUMP DRIVEN.	10G, 12G, 14G	1
0116-19	527159		GEAR, OIL PUMP DRIVEN (PRESSED ON SHAFT)	H, 3H, 4H	1
	461-404		KEY, WOODRUFF 1/8"X1/2"	10G, 12G, 14G	1
0116-20	518914		GEAR, OIL PUMP IDLER	10G, 12G, 14G	1
0116-20	527290		GEAR, OIL PUMP IDLER	H, 3H, 4H	1
0116-22	194592		THRUST WASHER, OIL PUMP DRIVE SHAFT.	10G, 12G, 14G	1
0116-27	529267		PIPE, OIL PUMP SUCTION	10G, 12G, 14G	1
0116-26	512709		SCREW, TO BLOCK 5/16"-18X3/4"	10G, 12G, 14G	2
	40X125		WASHER, LOCK 5/16"	10G, 12G, 14G	2
0116-28	194467		GASKET, OIL PUMP SUCTION PIPE.	10G, 12G, 14G	1
OIL STRAINER					
0116-30	187333		STRAINER AND HOUSING, OIL.	10G, 12G, 14G	1
0116-30	517691		STRAINER AND HOUSING, OIL.	H, 3H.	1
0116-30	532968		STRAINER AND HOUSING, OIL - W-F-Y-D-N.	4H.	1
0116-30	517691		STRAINER AND HOUSING, OIL - C-K.	4H.	1
	----		COTTER, TO PIPE 1/8"X1 1/4"	10G, 12G, 14G, H, 3H, 4H	1
OIL PRESSURE GAGE PIPES					
0116-33	527005		PIPE W/NUT, UPPER, OIL PRESSURE GAGE - LHC	10G, 12G	1
	526672		PIPE W/NUT, UPPER, OIL PRESSURE GAGE - RHC	10G, 12G	1
0116-33	532630		PIPE W/NUTS, UPPER, OIL PRESSURE GAGE.	14G	1
	182099		NUT, PIPE (GAGE END) 1/8"	10G, 12G, 14G	1
	----		NUT, PIPE (COUPLING END) 1/8"	10G, 12G, 14G	1
	172651		CLIP, TO DASH	10G, 12G, 14G	1
	614-#14-8		SCREW, TO DASH No. 14X1/2"	10G, 12G, 14G	1
0116-35	520400		PIPE W/NUTS, LOWER, OIL PRESSURE GAGE.	10G, 12G, 14G	1
	----		NUT, PIPE (COUPLING END) 3/16".	10G, 12G, 14G	1
	515-03		NUT, PIPE (CYL. END) 3/16".	10G, 12G, 14G	1
	643335		CLIP, TO ENGINE	10G, 12G, 14G	1
0116-33	526348		PIPE W/NUT, OIL PRESSURE GAGE - LHC.	H, 3H.	1
	526672		PIPE W/NUT, OIL PRESSURE GAGE - RHC.	H, 3H.	1
0116-33	532630		PIPE W/NUTS, OIL PRESSURE GAGE	4H.	1
	182099		NUT, PIPE 1/8" (GAGE END)	H, 3H, 4H	1
	----		NUT, PIPE 1/8" (COUPLING END)	H, 3H, 4H	1
	172651		CLIP, TO DASH	H, 3H, 4H	1
	614-#14-8		SCREW, TO DASH No. 14X1/2" - C-K	4H.	1

ENGINE

0118

ILLUST. NUMBER	PART NUMBER	CHANGE	DESCRIPTION	MODELS	PER CAR
----------------	-------------	--------	-------------	--------	---------

0116- OIL PUMP, STRAINER AND PRESSURE GAGE PIPES -Cont'd. (Plates 01-3, 5, 8)

OIL PRESSURE GAGE PIPES-Cont'd.

	520-03		ELBOW, GAGE PIPE TO OIL PUMP BODY.	10G, 12G, 14G	1
0116-39	522329		COUPLING, GAGE PIPE FLEXIBLE	10G, 12G, 14G	1
0116-39	530096		COUPLING, GAGE PIPE FLEXIBLE	H, 3H, 4H	1
	361-07		WASHER, PLAIN 7/16"	10G, 12G, 14G	1
1716-40	----		GROMMET, GAGE PIPE AND SPEEDO-SHAFT DASH (SEE GROUP 1716).	10G, 12G, H, 3H.	1
0116-42	293762		GROMMET, GAGE PIPE DASH - LHC.	12G, 3H.	1

0117- OIL PRESSURE RELEASE VALVE (Plates 01-3, 5)

0117-1	192136		VALVE, OIL PRESSURE RELIEF	10G, 12G, 14G, H, 3H, 4H	1
0117-3	192165		SPRING, RELIEF VALVE	10G, 12G, 14G, H, 3H, 4H	1
0117-6	192124		PLUG, RELIEF VALVE	10G, 12G, 14G	1
0117-6	527225		PLUG, RELIEF VALVE	H, 3H, 4H	1
0117-7	192125		GASKET, TO BLOCK.	10G, 12G, 14G, H, 3H, 4H	1

0118- OIL FILTER AND PIPES (Plates 01-3, 5)

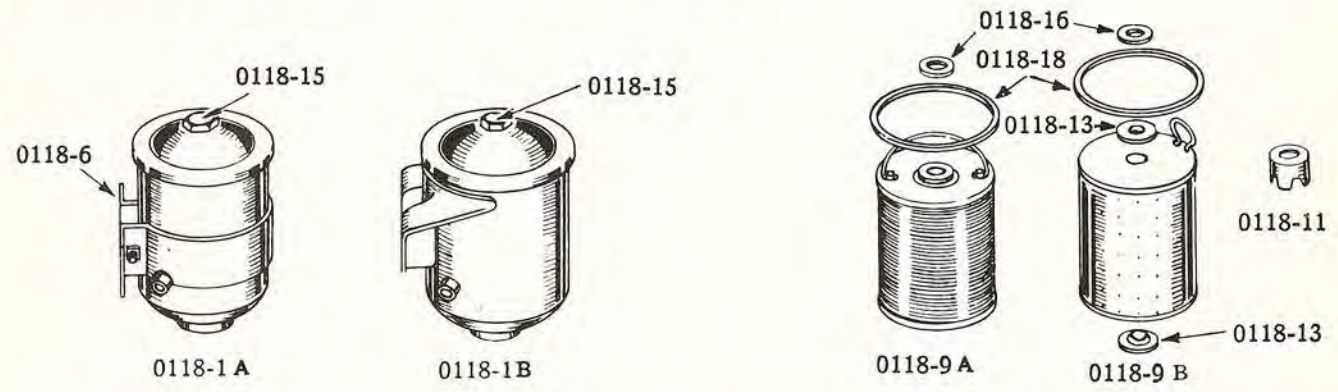

	AC-2130		MODEL F3-P2 OIL FILTER AND ATTACHING PARTS KIT	10G, 12G, 14G	1
	AC-2131		MODEL F4-P2 OIL FILTER AND ATTACHING PARTS KIT - HEAVY DUTY.	10G, 12G, 14G	1
	AC-2133		MODEL F4 OIL FILTER AND ATTACHING PARTS KIT.	H, 3H.	1
	AC-2310		MODEL F4 OIL FILTER AND ATTACHING PARTS KIT.	4H.	1
	AC-1842		ATTACHING PARTS KIT, OIL FILTER.	10G, 12G, 14G	1
0118-1A	519836		OIL FILTER - MODEL F3-P2	10G, 12G, 14G	1
0118-1B	519834		OIL FILTER - MODEL F4-P2 - HEAVY DUTY.	10G, 12G, 14G	1
	1-0512		BOLT, TO BRACKET 5/16"-18X3/4".	10G, 12G, 14G	2
	251-05		NUT, HEX. 5/16"-18	10G, 12G, 14G	2
	361-05		WASHER, PLAIN 5/16".	10G, 12G, 14G	2
	380-05		WASHER, LOCK 5/16"	10G, 12G, 14G	2
0118-1B	519834		OIL FILTER - MODEL F4.	H, 3H.	1
0118-1B	532572		OIL FILTER - MODEL F4.	4H.	1
	2-0512		BOLT, TO BRACKET 5/16"-24X3/4".	H, 3H, 4H	2
	252-05		NUT, HEX. 5/16"-24	H, 3H, 4H	2
	361-05		WASHER, PLAIN 5/16".	H, 3H, 4H	2
	380-05		WASHER, LOCK 5/16"	H, 3H, 4H	2

0118

ENGINE

ILLUST. NUMBER	PART NUMBER	CHANGE ✓	DESCRIPTION	MODELS	PER CAR
0118- OIL FILTER AND PIPES-Cont'd. (Plates 01-3, 5)					
0118-4	525926		BRACKET, OIL FILTER SUPPORT	10G, 12G, 14G	1
0118-4	530344		BRACKET, OIL FILTER SUPPORT	H, 3H.	1
0118-4	532563		BRACKET, OIL FILTER SUPPORT	4H.	1
0118-6	519837		STRAP, OIL FILTER MOUNTING (FOR F3-P2 FILTER)	10G, 12G, 14G	1
	55-0448		BOLT, CLAMPING 1/4"-20X3".	10G, 12G, 14G	1
	251-04		NUT, HEX. 1/4"-20	10G, 12G, 14G	1
	384-04		WASHER, LOCK 1/4"	10G, 12G, 14G	1
0118-9A	520829		CARTRIDGE KIT (FILCRON TYPE) (FOR F3-P2 FILTER) CONSISTS OF: 1----- CARTRIDGE 1-197485 COVER GASKET	10G, 12G, 14G	1
0118-9A	520830		CARTRIDGE KIT (FILCRON TYPE) (FOR F4-P2 FILTER) CONSISTS OF: 1----- CARTRIDGE 1-521945 COVER GASKET	10G, 12G, 14G	1
0118-9B	196646		CARTRIDGE KIT (WASTE TYPE) (FOR F4 FILTER) CONSISTS OF: . . . 1----- CARTRIDGE 2-198276 CARTRIDGE GASKET 1-521945 COVER GASKET	H, 3H, 4H	1
0118-11	520986		SUPPORT, OIL FILTER CARTRIDGE (FOR WASTE TYPE CARTRIDGE). . .	H, 3H, 4H	1
0118-13	198276		GASKET, OIL FILTER CARTRIDGE (INCL. IN 196646 KIT).	H, 3H, 4H	2
0118-15	198274		SCREW, OIL FILTER COVER 7/16"-20X1 1/4"	10G, 12G, H, 3H.	1
0118-16	192969		GASKET, SCREW.	10G, 12G, H, 3H.	1
0118-18	197485		GASKET, OIL FILTER COVER (FOR F3-P2 FILTER)	} INCL. IN CARTRIDGE KIT	10G, 12G, 14G
0118-18	521945		GASKET, OIL FILTER COVER (FOR F4 AND F4-P2 FILTER)		10G, 12G, H, 3H.
0118-21	521902		PIPE, INLET (FLEXIBLE).	10G, 12G, 14G	1
0118-21	530458		PIPE W/NUTS, INLET.	H, 3H.	1
0118-21	532564		PIPE W/NUTS, INLET.	4H.	1
	515-03		NUT, PIPE 3/16".	H, 3H, 4H	2
0118-22	521903		BRACKET AND CLAMP, INLET PIPE TO CYLINDER HEAD.	10G, 12G, 14G	1
	55-#10-7		BOLT, CLAMPING No. 10-24X7/16"	10G, 12G, 14G	1
	279-#10		NUT, HEX. No. 10-24	10G, 12G, 14G	1
	361-07		WASHER, PLAIN 7/16" (UNDER HEAD SCREW).	10G, 12G, 14G	1
	384-#10		WASHER, LOCK No. 10	10G, 12G, 14G	1
0118-25	525927		PIPE, OUTLET (FLEXIBLE)	10G, 12G, 14G	1
0118-25	530457		PIPE W/NUTS, OUTLET	H, 3H.	1
	532565		PIPE, OUTLET (FLEXIBLE)	4H.	1
	515-04		NUT, PIPE 1/4"	H, 3H.	2
	520-04		ELBOW, INLET PIPE (FILTER END).	10G, 12G, 14G	1
	520-03		ELBOW, INLET PIPE (FILTER END).	H, 3H, 4H	1
0118-30	530844		ELBOW, INLET PIPE (CYL. END).	H, 3H, 4H	1
	520-04		ELBOW, OUTLET PIPE.	10G, 12G, 14G, H, 3H, 4H	2