

SPEEDOMETER and INSTRUMENTS - Model 4H

1701

## SPEEDOMETER AND INSTRUMENTS

| ILLUST. NUMBER  | PART NUMBER | CHANGE | DESCRIPTION  | MODELS                          | PER CAR |
|---|-------------|--------|--|---------------------------------|---------|
| <b>1701- INSTRUMENT PANEL (Plates 17-1, 2, 3, 4, 5)</b> |             |        |  |                                 |         |
| 1701-1  | 530772      |        | PLATE, INSTRUMENTS MOUNTING (INCLUDES SPEEDOMETER BEZEL)<br>LHC. . . . .                 | 10G, 12G . . . . .              | 1       |
| 1701-1  | 526702      |        | PLATE, INSTRUMENTS MOUNTING - RHC . . . . .  | 10G, 12G . . . . .              | 1       |
| 1701-1  | 532587      |        | PLATE, INSTRUMENTS MOUNTING . . . . .  | 14G . . . . .                   | 1       |
| 1701-1  | 533664      |        | PLATE, INSTRUMENTS MOUNTING . . . . .  | 4H. . . . .                     | 1       |
|   | ----        |        | SCREW, TO INST. BOARD No. 8-32X3/16" . . . . .   | 14G . . . . .                   | 6       |
|   | ----        |        | SCREW AND WASHER, TO INST. BOARD No. 10-24X1/4" . . . . .                                | 4H. . . . .                     | 4       |
|   | 279-#10     |        | NUT, HEX. TO INST. BOARD No. 10-24 - LHC . . . . .                                       | 10G, 12G . . . . .              | 4       |
|   | 285930      |        | NUT, SPECIAL, TO INST. BOARD No. 10-24 - RHC . . . . .                                   | 10G, 12G . . . . .              | 4       |
|   | ----        |        | WASHER, LOCK No. 10 - LHC . . . . .  | 10G, 12G . . . . .              | 4       |
|   | 384-#10     |        | WASHER, SHAKEPROOF No. 10 - RHC . . . . .  | 10G, 12G . . . . .              | 4       |
| 1701-3  | 531243      |        | PLATE, SPEEDOMETER AND INSTRUMENTS BEZEL AND GLASS MOUNTING<br>- RHC. . . . .            | 10G, 12G . . . . .              | 1       |
| 1701-5  | 527194      |        | SPACER, TO MOUNTING PLATE - RHC. . . . .   | 10G, 12G . . . . .              | 1       |
| 1701-7  | 530767      |        | BEZEL, INSTRUMENTS PANEL - LHC. . . . .  | 10G, 12G . . . . .              | 1       |
| 1701-7  | 532586      |        | BEZEL, INSTRUMENTS PANEL. . . . .  | 14G . . . . .                   | 1       |
| 1701-7  | 533663      |        | BEZEL, INSTRUMENTS PANEL. . . . .  | 4H. . . . .                     | 4       |
|   | 533916      |        | SCREW, TO MAT No. 5-40X1/4" . . . . .  | 4H. . . . .                     | 12      |
| 1701-20   | 533662      |        | MAT, INSTRUMENTS. . . . .  | 4H. . . . .                     | 1       |
|   | ----        |        | SCREW, TO MOUNTING PLATE . . . . .   | 4H. . . . .                     | 4       |
| 1701-37   | 533669      |        | EMBLEM, INSTRUMENTS MAT . . . . .  | 4H. . . . .                     | 1       |
| 1701-12   | 530768      |        | GLASS, INSTRUMENTS PANEL - LHC. . . . .  | 10G, 12G . . . . .              | 1       |
| 1701-12   | 532588      |        | GLASS, INSTRUMENTS PANEL - LHC. . . . .  | 14G . . . . .                   | 1       |
| 1701-14   | 530769      |        | GASKET, RETAINER TO GLASS - LHC. . . . .   | 10G, 12G . . . . .              | 1       |
| 1701-14   | 533348      |        | GASKET, RETAINER TO GLASS - LHC. . . . .   | 14G . . . . .                   | 1       |
| 1701-15   | 530770      |        | RETAINER, GLASS - LHC. . . . .   | 10G, 12G . . . . .              | 1       |
| 1701-15   | 533349      |        | RETAINER, GLASS - LHC. . . . .   | 14G . . . . .                   | 1       |
| 1701-30   | 533350      |        | DIAL FACE, INSTRUMENTS - MILES. . . . .  | 14G . . . . .                   | 1       |
| 1701-30   | 533351      |        | DIAL FACE, INSTRUMENTS - METRIC . . . . .  | 14G . . . . .                   | 1       |
| 1701-31   | 533668      |        | DIAL FACE, OIL GAGE AND RADIMETER . . . . .  | 4H. . . . .                     | 1       |
| 1701-32   | 533667      |        | DIAL FACE, AMMETER AND GAS GAGE . . . . .  | 4H. . . . .                     | 1       |
| 1701-33   | 533665      |        | DIAL FACE, SPEEDOMETER - MILES. . . . .  | 4H. . . . .                     | 1       |
|   | 533666      |        | DIAL FACE, SPEEDOMETER - METRIC . . . . .  | 4H. . . . .                     | 1       |
| 1701-35   | 533661      |        | DIAL FACE, CLOCK HOLE. . . . .   | 4H. . . . .                     | 1       |
| 1701-17   | 530771      |        | MASK, INSTRUMENTS PANEL - LHC . . . . .  | 10G . . . . .                   | 1       |
| 1701-17   | 531730      |        | MASK, INSTRUMENTS PANEL - LHC . . . . .  | 12G . . . . .                   | 1       |
| 1701-17   | 532589      |        | MASK, INSTRUMENTS PANEL . . . . .  | 14G . . . . .                   | 1       |
|   | ----        |        | SOCKETS AND CABLES, INSTRUMENTS PANEL (PART OF CHASSIS<br>WIRING HARNESS) . . . . .      | 10G, 12G, 14G, 3H, 4H . . . . . | -       |
| 1701-20   | 526341      |        | SOCKETS AND CABLES, INSTRUMENTS PANEL - RHC . . . . .                                    | 10G, 12G . . . . .              | 1       |
| 1701-20   | 526342      |        | SOCKETS AND CABLES, INSTRUMENT PANEL. . . . .  | H . . . . .                     | 1       |
| 1701-20   | 526342      |        | SOCKETS AND CABLES, INSTRUMENTS PANEL - RHC . . . . .                                    | 3H. . . . .                     | 1       |
| 1701-21   | 192601      |        | SOCKETS AND CABLE, BRIGHT LIGHT SIGNAL LAMP . . . . .                                    | 10G, H . . . . .                | 1       |
|   | ----        |        | SOCKET AND CABLE, BRIGHT LIGHT SIGNAL LAMP (PART OF CHASSIS<br>WIRING HARNESS) . . . . . | 12G, 14G, 3H, 4H . . . . .      | -       |
|   | 192601      |        | SOCKET AND CABLE, BRIGHT LIGHT SIGNAL LAMP - RHC. . . . .                                | 12G, 3H. . . . .                | 1       |
|   | 526215      |        | SOCKET AND CABLE, MAP LIGHT . . . . .  | 10G, 12G, H, 3H. . . . .        | 1       |
|   | 192545      |        | CONNECTOR, BRIGHT LIGHT SIGNAL LAMP CABLE . . . . .                                      | 10G, H . . . . .                | 1       |
|   | 192545      |        | CONNECTOR, BRIGHT LIGHT SIGNAL LAMP CABLE - RHC . . . . .                                | 3H. . . . .                     | 1       |
|   | 185368      |        | BULB, INSTRUMENTS LAMP - MAZDA No. 55 . . . . .  | 10G, 12G . . . . .              | 4       |
|   | 188659      |        | BULB, INST. PANEL AND BRIGHT LIGHT SIGNAL LAMP - MAZDA No. 51 . . . . .                  | 14G . . . . .                   | 5       |
|   | 185368      |        | BULB, INSTRUMENTS LAMP - MAZDA No. 55 . . . . .  | H, 3H. . . . .                  | 2       |
|   | 188659      |        | BULB, INST. PANEL AND BRIGHT LIGHT SIGNAL LAMP - MAZDA No. 51 . . . . .                  | 4H. . . . .                     | 4       |
|   | 188659      |        | BULB, BRIGHT LIGHT SIGNAL LAMP - MAZDA No. 51 . . . . .                                  | 10G, 12G, H, 3H. . . . .        | 1       |
|   | 281149      |        | BULB, MAP LAMP - MAZDA No. 88L. . . . .  | 10G, 12G, H, 3H. . . . .        | 1       |

## SPEEDOMETER AND INSTRUMENTS

1707

| ILLUST. NUMBER   | PART NUMBER | CHANGE | DESCRIPTION   | MODELS                             | PER CAR |
|--|-------------|--------|---|------------------------------------|---------|
| <b>1701- INSTRUMENT PANEL-Cont'd. (Plates 17-1, 2, 3, 4, 5)</b>                          |             |        |   |                                    |         |
|  | 297696P     |        | PANEL, RIGHT, INSTRUMENTS CLUSTER . . . . .                 | 14G . . . . .                      | 1       |
|  | 297697P     |        | PANEL, LEFT, INSTRUMENTS CLUSTER. . . . .                   | 14G . . . . .                      | 1       |
|  | ****        |        | SCREW, FASTENING No. 8-32X1/4" . . . . .                    | 14G . . . . .                      | 4       |
|  | 297928P     |        | SHROUD, RIGHT, INSTRUMENTS CLUSTER. . . . .                 | 4H. . . . .                        | 1       |
|  | 297929P     |        | SHROUD, LEFT, INSTRUMENTS CLUSTER . . . . .                 | 4H. . . . .                        | 1       |
|  | 1023-#10-7  |        | SCREW, TO BOARD No. 10-32X7/16" . . . . .                   | 4H. . . . .                        | 1       |
|  | ****        |        | SCREW, TO PLATE No. 8X3/8" . . . . .                        | 4H. . . . .                        | 6       |
|  | 361-#10     |        | WASHER, PLAIN No. 10. . . . .                               | 4H. . . . .                        | 2       |
| <b>1702- COMBINATION OIL GAGE, AMMETER, GASOLINE GAGE AND RADIMETER (Plates 17-4, 5)</b> |             |        |   |                                    |         |
|  | ****        |        | OIL GAGE - SEE GROUP 1707 . . . . .                         | H, 3H. . . . .                     | 1       |
|  | ****        |        | AMMETER - SEE GROUP 1709. . . . .                           | H, 3H. . . . .                     | 1       |
|  | ****        |        | GASOLINE GAGE - SEE GROUP 1713. . . . .                     | H, 3H. . . . .                     | 1       |
|  | ****        |        | RADIMETER - SEE GROUP 1714. . . . .                         | H, 3H. . . . .                     | 1       |
| 1702-2   | 530731      |        | CASE, INSTRUMENTS MOUNTING. . . . .                         | H, 3H. . . . .                     | 1       |
| 1702-3   | 526644      |        | CLAMP, TO INSTRUMENT BOARD . . . . .                        | H, 3H. . . . .                     | 2       |
|  | 280-#10     |        | NUT, SPECIAL No. 10-32. . . . .                             | H, 3H. . . . .                     | 2       |
|  | 384-#10     |        | WASHER, LOCK No. 10 . . . . .                               | H, 3H. . . . .                     | 2       |
| 1702-5A  | 526140      |        | BEZEL, INSTRUMENTS MOUNTING CASE. . . . .                   | H . . . . .                        | 1       |
| 1702-5B  | 531803      |        | BEZEL, INSTRUMENTS MOUNTING CASE - LHC. . . . .             | 3H. . . . .                        | 1       |
|  | 526140      |        | BEZEL, INSTRUMENTS MOUNTING CASE - RHC. . . . .             | 3H. . . . .                        | 1       |
| 1702-6   | 526143      |        | GASKET, BEZEL TO GLASS - CORK. . . . .                      | H . . . . .                        | 1       |
| 1702-6   | 531805      |        | GASKET, BEZEL TO GLASS - CORK - LHC. . . . .                | 3H. . . . .                        | 1       |
|  | 526143      |        | GASKET, BEZEL TO GLASS - CORK - RHC. . . . .                | 3H. . . . .                        | 1       |
| 1702-7   | 526141      |        | GLASS, INSTRUMENTS. . . . .                                 | H, 3H. . . . .                     | 1       |
| 1702-9   | 526142      |        | GASKET, GLASS TO MASK - PAPER. . . . .                      | H, 3H. . . . .                     | 1       |
| 1702-11  | 530079      |        | MASK, INSTRUMENTS. . . . .                                  | H . . . . .                        | 1       |
| 1702-11  | 531906      |        | MASK, INSTRUMENTS - LHC . . . . .                           | 3H. . . . .                        | 1       |
|  | 530079      |        | MASK, INSTRUMENTS - RHC . . . . .                           | 3H. . . . .                        | 1       |
| <b>1705- COMBINATION OIL GAGE AND RADIMETER (Plates 17-1, 2, 3)</b>                      |             |        |   |                                    |         |
|  | ****        |        | OIL GAGE - SEE GROUP 1707 . . . . .                         | 10G, 12G . . . . .                 | 1       |
|  | ****        |        | RADIMETER - SEE GROUP 1714. . . . .                         | 10G, 12G . . . . .                 | 1       |
| 1705-1   | 530775      |        | CASE, OIL GAGE AND RADIMETER MOUNTING - LHC . . . . .       | 10G, 12G . . . . .                 | 1       |
| 1705-1   | 526715      |        | CASE, OIL GAGE AND RADIMETER MOUNTING - RHC . . . . .       | 10G, 12G . . . . .                 | 1       |
|  | 55-#8-3     |        | SCREW, TO MOUNTING PLATE No. 8-32X3/16" . . . . .           | 10G, 12G . . . . .                 | 2       |
| 1705-4   | 526720      |        | BEZEL, OIL GAGE AND RADIMETER - RHC . . . . .               | 10G, 12G . . . . .                 | 1       |
| 1705-7   | 526721      |        | GLASS, OIL GAGE AND RADIMETER - RHC . . . . .               | 10G, 12G . . . . .                 | 1       |
| 1705-9   | 526722      |        | GASKET, GLASS - CORK . . . . .                              | 10G, 12G . . . . .                 | 1       |
| <b>1707- OIL PRESSURE GAGE (Plates 17-1, 2, 3, 4, 5)</b>                                 |             |        |   |                                    |         |
| 1707-1   | 530050      |        | GAGE, OIL PRESSURE - LHC. . . . .                           | 10G, 12G . . . . .                 | 1       |
| 1707-1   | 526718      |        | GAGE, OIL PRESSURE - RHC. . . . .                           | 10G, 12G . . . . .                 | 1       |
| 1707-1   | 526735      |        | GAGE, OIL PRESSURE. . . . .                                 | H, 3H. . . . .                     | 1       |
| 1707-1   | 532596      |        | GAGE, OIL PRESSURE. . . . .                                 | 14G, 4H. . . . .                   | 1       |
| 1707-3   | 672807      |        | NUT, TO MOUNTING PLATE 1/2"-20 . . . . .                    | 10G, 12G, 14G, H, 3H, 4H . . . . . | 1       |
|  | ****        |        | PLATE, OIL GAGE MOUNTING - SEE GROUP 1709 . . . . .         | 14G, 4H. . . . .                   | 1       |
|  | ****        |        | DIAL FACE, OIL GAGE AND RADIMETER - SEE GROUP 1701. . . . . | 14G, H, 3H, 4H . . . . .           | 1       |

1709

## SPEEDOMETER AND INSTRUMENTS

| ILLUST. NUMBER   | PART NUMBER | CHANGE<br>✓ | DESCRIPTION  | MODELS                   | PER CAR |
|--|-------------|-------------|--|--------------------------|---------|
| <b>1709- AMMETER (Plates 17-1, 2, 3, 4, 5)</b>                         |             |             |  |                          |         |
| 1709-1   | 530047      |             | AMMETER - LHC . . . . .                                      | 10G, 12G . . . . .       | 1       |
| 1709-1   | 526716      |             | AMMETER - RHC . . . . .                                      | 10G, 12G . . . . .       | 1       |
| 1709-1   | 526734      |             | AMMETER . . . . .  | H, 3H. . . . .           | 1       |
| 1709-1   | 532591      |             | AMMETER . . . . .  | 14G, 4H. . . . .         | 1       |
| 1709-3   | 526970      |             | NUT, TO MOUNTING PLATE No. 10-32 . . . . .                   | 10G, 12G, 14G, H, 3H, 4H | 2       |
|  | 280-#10     |             | NUT, TERMINAL No. 10-32. . . . .                             | 10G, 12G, 14G, H, 3H, 4H | 2       |
|  | 361-#10     |             | WASHER, TERMINAL PLAIN No. 10 . . . . .                      | 10G, 12G, 14G, H, 3H, 4H | 2       |
|  | 380-#10     |             | WASHER, TERMINAL LOCK No. 10. . . . .                        | 10G, 12G, 14G, H, 3H, 4H | 2       |
| 1709-7   | 526733      |             | PLATE, AMMETER AND OIL GAGE MOUNTING. . . . .                | H, 3H. . . . .           | 1       |
| 1709-7   | 533654      |             | PLATE, AMMETER AND GAS GAGE MOUNTING. . . . .                | 14G, 4H. . . . .         | 1       |
| 1709-8   | 526724      |             | STUD, TO CASE No. 10-32X15/16" . . . . .                     | H, 3H. . . . .           | 1       |
|  | 55-#8-3     |             | SCREW, TO CASE No. 8-32X3/16". . . . .                       | 14G, H, 3H, 4H . . . . . | 1       |
|  | ----        |             | DIAL FACE, AMMETER AND GAS GAGE - SEE GROUP 1701. . . . .    | 14G, 4H. . . . .         | 1       |
| 1709-9   | 173170      |             | INSULATOR, AMMETER POST - PORCELAIN . . . . .                | 10G, 12G, 14G, H, 3H, 4H | 2       |
| 1709-10  | 527021      |             | INSULATOR, AMMETER POST - FIBRE . . . . .                    | 10G, 12G . . . . .       | 1       |
| 1709-10  | 526723      |             | INSULATOR, AMMETER POST - FIBRE . . . . .                    | H, 3H. . . . .           | 1       |
| 1709-10  | 532592      |             | INSULATOR, AMMETER POST - FIBRE . . . . .                    | 14G, 4H. . . . .         | 1       |
| <b>1712- COMBINATION GASOLINE GAGE AND AMMETER (Plates 17-1, 2, 3)</b> |             |             |  |                          |         |
|  | ----        |             | GASOLINE GAGE - SEE GROUP 1713. . . . .                      | 10G, 12G . . . . .       | 1       |
|  | ----        |             | AMMETER - SEE GROUP 1709. . . . .                            | 10G, 12G . . . . .       | 1       |
| 1712-1   | 530774      |             | CASE, GASOLINE GAGE AND AMMETER - LHC . . . . .              | 10G, 12G . . . . .       | 1       |
| 1712-1   | 526713      |             | CASE, GASOLINE GAGE AND AMMETER - RHC . . . . .              | 10G, 12G . . . . .       | 1       |
|  | ----        |             | SCREW, TO MOUNTING PLATE No. 8-32X3/16". . . . .             | 10G, 12G . . . . .       | 2       |
| 1712-4   | 526720      |             | BEZEL, GASOLINE GAGE AND AMMETER - RHC. . . . .              | 10G, 12G . . . . .       | 1       |
| 1712-7   | 526721      |             | GLASS, GASOLINE GAGE AND AMMETER - RHC. . . . .              | 10G, 12G . . . . .       | 1       |
| 1712-9   | 526722      |             | GASKET, BEZEL - CORK . . . . .                               | 10G, 12G . . . . .       | 1       |
| <b>1713- GASOLINE GAGE (Plates 17-1, 2, 3, 4, 5)</b>                   |             |             |  |                          |         |
| 1713-1   | 530048      |             | GAGE, GASOLINE - LHC. . . . .                                | 10G, 12G . . . . .       | 1       |
| 1713-1   | 526717      |             | GAGE, GASOLINE - RHC. . . . .                                | 10G, 12G . . . . .       | 1       |
| 1713-1   | 526738      |             | GAGE, GASOLINE. . . . .                                      | H, 3H. . . . .           | 1       |
| 1713-1   | 532593      |             | GAGE, GASOLINE. . . . .                                      | 14G, 4H. . . . .         | 1       |
| 1713-3   | 526970      |             | NUT, TO MOUNTING PLATE No. 10-32 . . . . .                   | 10G, 12G, 14G, H, 3H, 4H | 2       |
|  | 280-#10     |             | NUT, TERMINAL No. 10-32. . . . .                             | 10G, 12G, 14G, H, 3H, 4H | 2       |
|  | 361-#10     |             | WASHER, TERMINAL PLAIN No. 10 . . . . .                      | 10G, 12G, H, 3H. . . . . | 2       |
|  | ----        |             | WASHER, TERMINAL LOCK No. 10. . . . .                        | 10G, 12G, 14G, H, 3H, 4H | 2       |
|  | ----        |             | PLATE, RADIMETER AND GASOLINE GAGE MOUNTING - SEE GROUP 1714 | 14G, H, 3H, 4H . . . . . | 1       |
|  | ----        |             | DIAL FACE, AMMETER AND GAS GAGE - SEE GROUP 1701. . . . .    | 14G, 4H. . . . .         | 1       |
| 1713-10  | 527020      |             | INSULATOR, GASOLINE GAGE POST - FIBRE . . . . .              | 10G, 12G . . . . .       | 1       |
|  | ----        |             | INSULATOR, RADIMETER AND GASOLINE GAGE POST - SEE GROUP 1714 | H, 3H. . . . .           | 1       |
| 1713-10  | 532594      |             | INSULATOR, GAS GAGE - FIBRE . . . . .                        | 14G, 4H. . . . .         | 1       |

## SPEEDOMETER AND INSTRUMENTS

1716

| ILLUST. NUMBER  | PART NUMBER | CHANGE | DESCRIPTION   | MODELS                             | PER CAR |
|---|-------------|--------|---|------------------------------------|---------|
| <b>1714- RADIMETER OR WATER TEMPERATURE INDICATOR</b>                   |             |        |   |                                    |         |
| (Plates 17-1, 2, 3)   |             |        |   |                                    |         |
| 1714-1  | 530051      |        | RADIMETER - DASH UNIT - LHC . . . . .                         | 10G, 12G . . . . .                 | 1       |
| 1714-1  | 526719      |        | RADIMETER - DASH UNIT - RHC . . . . .                         | 10G, 12G . . . . .                 | 1       |
| 1714-1  | 526739      |        | RADIMETER - DASH UNIT . . . . .                               | H, 3H . . . . .                    | 1       |
| 1714-1  | 532597      |        | RADIMETER - DASH UNIT . . . . .                               | 14G, 4H . . . . .                  | 1       |
| 1714-3  | 526970      |        | NUT, TO MOUNTING PLATE No. 10-32 . . . . .                    | 10G, 12G, 14G, H, 3H, 4H . . . . . | 2       |
|   | 280-#10     |        | NUT, TERMINAL No. 10-32 . . . . .                             | 10G, 12G, 14G, H, 3H, 4H . . . . . | 2       |
|   | 361-#10     |        | WASHER, TERMINAL PLAIN No. 10 . . . . .                       | 10G, 12G, 14G, H, 3H, 4H . . . . . | 2       |
|   | ----        |        | WASHER, TERMINAL LOCK No. 10 . . . . .                        | 10G, 12G, 14G, H, 3H, 4H . . . . . | 2       |
| 1714-9  | 526737      |        | PLATE, RADIMETER AND GASOLINE GAGE MOUNTING . . . . .         | H, 3H . . . . .                    | 1       |
| 1714-9  | 533655      |        | PLATE, RADIMETER AND OIL GAGE MOUNTING . . . . .              | 14G, 4H . . . . .                  | 1       |
| 1714-10   | 526724      |        | STUD, TO CASE No. 10-32X15/16" . . . . .                      | H, 3H . . . . .                    | 1       |
|   | ----        |        | SCREW, TO CASE No. 8-32X3/16" . . . . .                       | 14G, H, 3H, 4H . . . . .           | 2       |
|   | ----        |        | DIAL FACE, RADIMETER AND OIL GAGE - SEE GROUP 1701 . . . . .  | 14G, 4H . . . . .                  | 1       |
| 1714-11   | 527020      |        | INSULATOR, RADIMETER POST - FIBRE . . . . .                   | 10G, 14G, H, 4H . . . . .          | 1       |
| 1714-11   | 526971      |        | INSULATOR, RADIMETER AND GASOLINE GAGE POST - FIBRE . . . . . | H, 3H . . . . .                    | 1       |
| <b>1716- SPEEDOMETER AND DRIVE PARTS (Plates 17-1, 2, 3, 4, 5)</b>      |             |        |   |                                    |         |
| SPEEDOMETER HEADS MAY BE REPAIRED AT ANY<br>AUTHORIZED SERVICE STATION. |             |        |   |                                    |         |
| 1716-1  | 530044      |        | SPEEDOMETER (HEAD) MILES - LHC . . . . .                      | 10G, 12G . . . . .                 | 1       |
|   | 530045      |        | SPEEDOMETER (HEAD) METRIC - LHC . . . . .                     | 10G, 12G . . . . .                 | 1       |
| 1716-1  | 526703      |        | SPEEDOMETER (HEAD) MILES - RHC . . . . .                      | 10G, 12G . . . . .                 | 1       |
|   | 526704      |        | SPEEDOMETER (HEAD) METRIC - RHC . . . . .                     | 10G, 12G . . . . .                 | 1       |
| 1716-1  | 530077      |        | SPEEDOMETER (HEAD) MILES (INCLUDES CLAMPS) . . . . .          | H . . . . .                        | 1       |
|   | 530078      |        | SPEEDOMETER (HEAD) METRIC (INCLUDES CLAMPS) . . . . .         | H . . . . .                        | 1       |
| 1716-1  | 531801      |        | SPEEDOMETER (HEAD) MILES (INCLUDES CLAMPS) LHC . . . . .      | 3H . . . . .                       | 1       |
|   | 531802      |        | SPEEDOMETER (HEAD) METRIC (INCLUDES CLAMPS) LHC . . . . .     | 3H . . . . .                       | 1       |
| 1716-1  | 530077      |        | SPEEDOMETER (HEAD) MILES (INCLUDES CLAMPS) RHC . . . . .      | 3H . . . . .                       | 1       |
|   | 530078      |        | SPEEDOMETER (HEAD) METRIC (INCLUDES CLAMPS) RHC . . . . .     | 3H . . . . .                       | 1       |
| 1716-1  | 532598      |        | SPEEDOMETER (HEAD) MILES . . . . .                            | 14G, 4H . . . . .                  | 1       |
| 1716-1  | 532599      |        | SPEEDOMETER (HEAD) METRIC . . . . .                           | 14G, 4H . . . . .                  | 1       |
| 1716-1-1  | 526644      |        | CLAMP, TO INSTRUMENT BOARD . . . . .                          | H, 3H . . . . .                    | 2       |
|   | 55-#8-3     |        | SCREW, TO MOUNTING PLATE No. 8-32X3/16" . . . . .             | 10G, 12G . . . . .                 | 4       |
|   | 280-#10     |        | NUT, HEX. No. 10-32 . . . . .                                 | H, 3H . . . . .                    | 2       |
|   | 384-#10     |        | WASHER, SHAKEPROOF No. 10 . . . . .                           | H, 3H . . . . .                    | 2       |
|   | 55-#8-8     |        | SCREW, TO CASE No. 8-32X1/2" . . . . .                        | 14G, 4H . . . . .                  | 2       |
|   | 384-#8      |        | WASHER, SHAKEPROOF No. 8 . . . . .                            | 14G, 4H . . . . .                  | 2       |
| 1716-2  | 530773      |        | CASE, SPEEDOMETER (OR BASE) LHC . . . . .                     | 10G, 12G . . . . .                 | 1       |
| 1716-2  | 526708      |        | CASE, SPEEDOMETER (OR BASE) RHC . . . . .                     | 10G, 12G . . . . .                 | 1       |
| 1716-2  | 530732      |        | CASE, SPEEDOMETER (OR BASE) . . . . .                         | H, 3H . . . . .                    | 1       |
|   | ----        |        | CASE, SPEEDOMETER (OR BASE) USE SPEEDOMETER . . . . .         | 14G, 4H . . . . .                  | 1       |
|   | 55-#8-8     |        | SCREW, TO CHASSIS No. 8-32X1/2" . . . . .                     | 10G, 12G, H, 3H . . . . .          | 2       |
|   | 55-#8-8     |        | SCREW, TO PLATE No. 8-32X1/2" . . . . .                       | 14G, 4H . . . . .                  | 3       |
|   | 361-#8      |        | WASHER, PLAIN No. 8 . . . . .                                 | H, 3H . . . . .                    | 2       |
|   | 384-#8      |        | WASHER, SHAKEPROOF No. 8 . . . . .                            | 10G, 12G . . . . .                 | 2       |
|   | ----        |        | WASHER, SHAKEPROOF No. 8 . . . . .                            | H, 3H . . . . .                    | 2       |
| 1716-5A   | 526140      |        | BEZEL, SPEEDOMETER . . . . .                                  | H . . . . .                        | 1       |
| 1716-5B   | 531804      |        | BEZEL, SPEEDOMETER - LHC . . . . .                            | 3H . . . . .                       | 1       |
|   | 526140      |        | BEZEL, SPEEDOMETER - RHC . . . . .                            | 3H . . . . .                       | 1       |
|   | ----        |        | BEZEL, SPEEDOMETER - SEE GROUP 1701 . . . . .                 | 4H . . . . .                       | 1       |
| 1716-6  | 526143      |        | GASKET, BEZEL TO GLASS - CORK . . . . .                       | H . . . . .                        | 1       |
| 1716-6  | 531805      |        | GASKET, BEZEL TO GLASS - CORK - LHC . . . . .                 | 3H . . . . .                       | 1       |
|   | 526143      |        | GASKET, BEZEL TO GLASS - CORK - RHC . . . . .                 | 3H . . . . .                       | 1       |

1716

# SPEEDOMETER AND INSTRUMENTS

| ILLUST. NUMBER                                   | PART NUMBER | CHANGE | DESCRIPTION   | MODELS                   | PER CAR |
|--|-------------|--------|---|--------------------------|---------|
| <b>1716- SPEEDOMETER AND DRIVE PARTS-Cont'd.</b> |             |        |   |                          |         |
| (Plates 17-1, 2, 3, 4, 5)                        |             |        |   |                          |         |
| 1716-7   | 526709      |        | GLASS, SPEEDOMETER - RHC.   | 10G, 12G                 | 1       |
| 1716-7   | 526141      |        | GLASS, SPEEDOMETER.   | H, 3H.                   | 1       |
| 1716-8   | 526711      |        | RETAINER, GLASS TO MOUNTING PLATE - RHC.                                | 10G, 12G                 | 1       |
| 1716-8   | 530080      |        | RETAINER, GLASS TO BEZEL (INCLUDES BUTTON)                              | H                        | 1       |
| 1716-8   | 531907      |        | RETAINER, GLASS TO BEZEL (INCLUDES BUTTON) - LHC                        | 3H.                      | 1       |
| 1716-8   | 530080      |        | RETAINER, GLASS TO BEZEL (INCLUDES BUTTON) - RHC                        | 3H.                      | 1       |
| 1716-9   | 526710      |        | GASKET, SPEEDOMETER GLASS TO RETAINER AND MOUNTING PLATE - PAPER - RHC. | 10G, 12G                 | 2       |
| 1716-9   | 526142      |        | GASKET, SPEEDOMETER GLASS TO RETAINER - PAPER.                          | H, 3H.                   | 1       |
| ----   |             |        | DIAL FACE, SPEEDOMETER - SEE GROUP 1701                                 | 14G, 4H.                 | 1       |
| 1716-15  | ----        |        | CHASSIS, SPEEDOMETER (USE SPEEDOMETER).                                 | 10G, 12G, 14G, H, 3H, 4H | 1       |

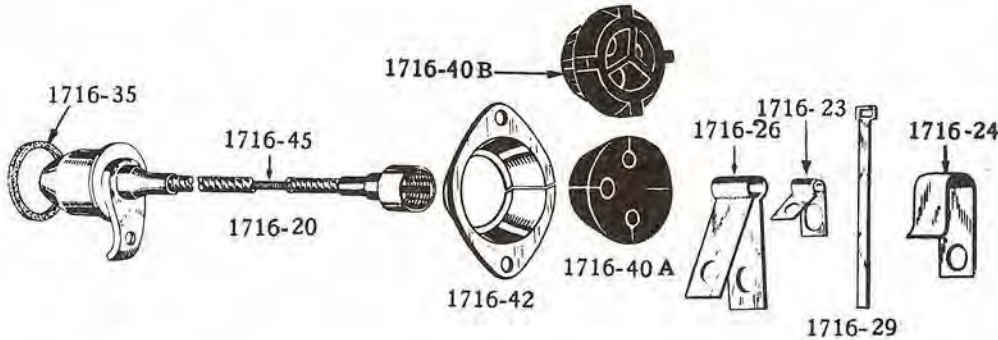

| ILLUST. NUMBER | PART NUMBER | DESCRIPTION   | LENGTH | MODELS                   | PER CAR |
|----------------|-------------|---|--------|--------------------------|---------|
| 1716-20        | 519782      | SHAFT W/CORE, SPEEDOMETER (WITH ST) LHC             | 58"    | 10G, 12G, 14G, H, 3H.    | 1       |
| 1716-20        | 519782      | SHAFT W/CORE, SPEEDOMETER (WITH ST) - W-F-Y - LHC   | 58"    | 4H.                      | 1       |
| 1716-20        | 526369      | SHAFT W/CORE, SPEEDOMETER (WITH ST) - C-K - LHC     | 62"    | 4H.                      | 1       |
| 1716-20        | 519782      | SHAFT W/CORE, SPEEDOMETER (WITH OD) - LHC - NOTE 1. | 58"    | 10G, H                   | 1       |
| 1716-20        | 526371      | SHAFT W/CORE, SPEEDOMETER (WITH OD) - LHC - NOTE 2. | 55"    | 10G, 12G, H, 3H.         | 1       |
| 1716-20        | 526371      | SHAFT W/CORE, SPEEDOMETER (WITH OD) - W-F - LHC     | 55"    | 14G                      | 1       |
| 1716-20        | 519782      | SHAFT W/CORE, SPEEDOMETER (WITH OD) - C-K - LHC     | 58"    | 14G                      | 1       |
| 1716-20        | 526369      | SHAFT W/CORE, SPEEDOMETER (WITH OD) - LHC           | 62"    | 4H.                      | 1       |
| 1716-20        | 527523      | SHAFT W/CORE, SPEEDOMETER (WITH AD) - LHC           | 47"    | 10G, 12G, H, 3H.         | 1       |
| 1716-20        | 526371      | SHAFT W/CORE, SPEEDOMETER (WITH AD) - LHC           | 55"    | 14G                      | 1       |
| 1716-20        | 527523      | SHAFT W/CORE, SPEEDOMETER (WITH AD) - W-F-Y - LHC   | 47"    | 4H.                      | 1       |
| 1716-20        | 526371      | SHAFT W/CORE, SPEEDOMETER (WITH AD) - C-K - LHC     | 55"    | 4H.                      | 1       |
| 1716-20        | 526369      | SHAFT W/CORE, SPEEDOMETER (WITH OD) - RHC           | 62"    | 10G, 12G, H, 3H.         | 1       |
| 1716-20        | 519784      | SHAFT W/CORE, SPEEDOMETER (WITH OD) - RHC           | 70"    | 14G, 4H.                 | 1       |
| 1716-20        | 530841      | SHAFT W/CORE, SPEEDOMETER (LESS OD) - RHC           | 52"    | 10G, 12G, H, 3H.         | 1       |
| 1716-20        | 526601      | SHAFT W/CORE, SPEEDOMETER (LESS OD) - W-F - RHC     | 44"    | 14G                      | 1       |
| 1716-20        | 530841      | SHAFT W/CORE, SPEEDOMETER (LESS OD) - W-F-Y - RHC   | 52"    | 4H.                      | 1       |
|                | 1-0412      | SCREW, TO TRANSMISSION 1/4"-20X3/4"                 |        | 10G, 12G, 14G, H, 3H, 4H | 1       |
|                | ----        | WASHER, LOCK 1/4"                                   |        | 10G, 12G, 14G, H, 3H, 4H | 1       |
| 1716-26        | 188000      | CLIP, CLOSED, TO FLOOR PAN                          |        | 10G, H                   | 1       |
| 1716-24        | 182050      | CLIP, OPEN, TO CONVERTER HOUSING                    |        | 10G, 12G, H, 3H.         | 1       |
| 1716-23        | 529401      | CLIP, CLOSED, TO DASH.                              |        | 10G, 12G, H, 3H.         | 2       |
| 1716-23        | 529401      | CLIP, CLOSED, TO FLOOR - RHC                        |        | 10G, 12G, H, 3H.         | 1       |
| 1716-29        | 526600X4    | CLIP, LACER 3" LONG                                 |        | 10G, H                   | 1       |
|                | 614-#14-8   | SCREW, TO DASH No. 14X1/2"                          |        | 10G, 12G, H, 3H.         | 2       |
|                | 1811X3      | SPEED NUT, TO DASH No. 14                           |        | 10G, 12G, H, 3H.         | 1       |
|                | 529401      | CLIP, CLOSED, TO DASH.                              |        | 14G                      | 2       |
|                | 188000      | CLIP, CLOSED, TO DASH AND FLOOR PAN - LHC } WITH ST |        | 4H.                      | 1       |

FASTENING PARTS CONTINUED ON PAGE 279.

NOTES { 1 - USED ON MODELS 10G | H  
BEFORE CAR SERIALS G-1,006,805 | 8,110,936  
2 - USED ON AND AFTER CAR SERIALS IN NOTE 1.

# SPEEDOMETER AND INSTRUMENTS

1718

| ILLUST. NUMBER                                   | PART NUMBER | CHANGE | DESCRIPTION   | MODELS                        | PER CAR |
|--|-------------|--------|---|-------------------------------|---------|
| <b>1718- SPEEDOMETER AND DRIVE PARTS-Cont'd.</b> |             |        |   |                               |         |
| <b>(Plates 17-1, 2, 3, 4, 5)</b>                 |             |        |   |                               |         |
|  | 188000      |        | CLIP, CLOSED, TO FLOOR PAN - RHC . . . . .                        | 14G . . . . .                 | 1       |
|  | 182050      |        | CLIP, CLOSED, TO FLOOR PAN - RHC . . . . .                        | 4H . . . . .                  | 1       |
| 615-#14-8  |             |        | SCREW, TO DASH No. 14X1/2" . . . . .                              | 14G, 4H. . . . .              | 1       |
| ----   |             |        | SCREW, TO FLOOR PAN 1/4"X20X5/8" . . . . .                        | 14G, 4H. . . . .              | 1       |
| 251-04   |             |        | NUT, SQUARE 1/4"-20 . . . . .                                     | 14G, 4H. . . . .              | 1       |
| ----   |             |        | WASHER, LOCK 1/4" . . . . .                                       | 14G, 4H. . . . .              | 1       |
| 529401   |             |        | CLIP, CLOSED TO FLOOR PAN W.F. . . . .                            | 14G, 4H. . . . .              | 1       |
| 529401   |             |        | CLIP, CLOSED, TO DASH - RHC. . . . .                              | 14G, 4H. . . . .              | 1       |
| 651-#14-8  |             |        | SCREW, TO FLOOR PAN No. 14X1/2" . . . . .                         | 14G . . . . .                 | 1       |
| 511382   |             |        | CLIP, TO CONVERTER HOUSING . . . . .                              | 14G, 4H. . . . .              | 1       |
| 511382   |             |        | CLIP, TO ACCELERATOR BRACKET } WITH AD . . . . .                  | 4H. . . . .                   | 1       |
| 1716-35  | 515701      |        | GASKET, SPEEDOMETER SHAFT - CORK 1" I.D. X1 1/4" O.D. . . . .     | 10G, 12G, 14G, H, 3H, 4H      | 1       |
| 1716-40A   | 523232      |        | GROMMET, SPEEDOMETER SHAFT - RUBBER . . . . .                     | 10G, H . . . . .              | 1       |
| 1716-40B   | 531871      |        | GROMMET, SPEEDOMETER SHAFT - RUBBER . . . . .                     | 12G, 3H. . . . .              | 1       |
| 1716-40B   | 532857      |        | GROMMET, SPEEDOMETER SHAFT - RUBBER . . . . .                     | 14G, 4H. . . . .              | 1       |
| 1716-42  | 195803      |        | RETAINER, TO DASH. . . . .  | 10G, H . . . . .              | 1       |
| 614-#10-8  |             |        | SCREW, No. 10X1/2" . . . . .                                      | 10G, H . . . . .              | 2       |
| <b>LENGTH</b>                                    |             |        |   |                               |         |
| 1716-45  | 519783      |        | CORE, SPEEDOMETER SHAFT (WITH ST) LHC . . . . . 58 15/16"         | 10G, 12G, 14G, H, 3H. . . . . | 1       |
| 1716-45  | 519783      |        | CORE, SPEEDOMETER SHAFT (WITH ST) W-F-Y - LHC . . . . . 58 15/16" | 4H. . . . .                   | 1       |
| 1716-45  | 526370      |        | CORE, SPEEDOMETER SHAFT (WITH ST) C-K - LHC . . . . . 62 15/16"   | 4H. . . . .                   | 1       |
| 1716-45  | 519783      |        | CORE, SPEEDOMETER SHAFT (WITH OD) LHC - NOTE 1. . . . . 58 15/16" | 10G, H . . . . .              | 1       |
| 1716-45  | 526372      |        | CORE, SPEEDOMETER SHAFT (WITH OD) LHC - NOTE 2. . . . . 55 3/4"   | 10G, 12G, H, 3H. . . . .      | 1       |
| 1716-45  | 526372      |        | CORE, SPEEDOMETER SHAFT (WITH OD) W-F - LHC . . . . . 55 3/4"     | 14G . . . . .                 | 1       |
| 1716-45  | 519783      |        | CORE, SPEEDOMETER SHAFT (WITH OD) C-K - LHC . . . . . 58 15/16"   | 14G . . . . .                 | 1       |
| 1716-45  | 526370      |        | CORE, SPEEDOMETER SHAFT (WITH OD) LHC . . . . . 62 15/16"         | 4H. . . . .                   | 1       |
| 1716-45  | 527524      |        | CORE, SPEEDOMETER SHAFT (WITH AD) LHC . . . . . 47 3/4"           | 10G, 12G, H, 3H. . . . .      | 1       |
| 1716-45  | 526372      |        | CORE, SPEEDOMETER SHAFT (WITH AD) LHC . . . . . 55 3/4"           | 14G . . . . .                 | 1       |
| 1716-45  | 527524      |        | CORE, SPEEDOMETER SHAFT (WITH AD) W-F-Y - LHC . . . . . 47 3/4"   | 4H. . . . .                   | 1       |
| 1716-45  | 526372      |        | CORE, SPEEDOMETER SHAFT (WITH AD) LHC . . . . . 55 3/4"           | 14G . . . . .                 | 1       |
| 1716-45  | 526370      |        | CORE, SPEEDOMETER SHAFT (WITH OD) RHC . . . . . 62 15/16"         | 10G, 12G, H, 3H. . . . .      | 1       |
| 1716-45  | 519785      |        | CORE, SPEEDOMETER SHAFT (WITH OD) RHC . . . . . 70 3/4"           | 14G, 4H. . . . .              | 1       |
| 1716-45  | 530842      |        | CORE, SPEEDOMETER SHAFT (LESS OD) RHC . . . . . 52 3/4"           | 10G, 12G, H, 3H. . . . .      | 1       |
| 1716-45  | 526602      |        | CORE, SPEEDOMETER SHAFT (LESS OD) RHC . . . . . 44 13/16"         | 14G . . . . .                 | 1       |
| 1716-45  | 530842      |        | CORE, SPEEDOMETER SHAFT (LESS OD) RHC . . . . . 52 3/4"           | 4H. . . . .                   | 1       |
| 1716-30  | ----        |        | GEAR, SPEEDOMETER DRIVE } SEE SPEEDOMETER GEAR . . . . .          | 10G, 12G, 14G, H, 3H, 4H      | 1       |
| 1716-31  | ----        |        | PINION, SPEEDOMETER DRIVE } AND PINION CHART . . . . .            | 10G, 12G, 14G, H, 3H, 4H      | 1       |

NOTES { 1 - USED ON MODELS 10G | H  
BEFORE CAR SERIALS G-1,006,805 | 8,110,936  
2 - USED ON AND AFTER CAR SERIALS IN NOTE 1.

1716

# SPEEDOMETER AND INSTRUMENTS

| ILLUST. NUMBER | PART NUMBER | CHANGE | DESCRIPTION | MODELS | PER CAR |
|----------------|-------------|--------|-------------|--------|---------|
|----------------|-------------|--------|-------------|--------|---------|

## 1716- SPEEDOMETER AND DRIVE PARTS-Cont'd. (Plates 17-1, 2, 3, 4, 5)

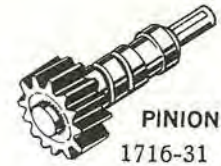

### SPEEDOMETER GEAR AND PINION CHART

ST - For cars with standard transmission  
OD - For cars with overdrive transmission  
AD - For cars with automatic transmission

| MODEL         | AXLE RATIO | ST   |        |       |        | OD   |      |        |        | AD     |      |       |        |    |        |    |
|---------------|------------|------|--------|-------|--------|------|------|--------|--------|--------|------|-------|--------|----|--------|----|
|               |            | TYPE | GEAR   | TEETH | PINION | TYPE | GEAR | TEETH  | PINION | TYPE   | GEAR | TEETH | PINION |    |        |    |
| 10G, 12G      | 3.54       |      |        |       |        |      |      |        |        |        |      |       |        |    |        |    |
| 10G, 12G, 14G | 4.1        | A    | 520082 | 5     | 520088 | 16   | B    | 520084 | 5      | 520088 | 16   | C     | 531040 | 10 | 527689 | 23 |
| 10G, 12G, 14G | 4.56       | A    | 520082 | 5     | 520089 | 17   | B    | 520084 | 5      | 520089 | 17   | C     | 531040 | 10 | 531202 | 26 |
| 10G, 12G, 14G | 4.88       |      |        |       |        |      | B    | 520084 | 5      | 520090 | 18   |       |        |    |        |    |
| H, 3H, 4H     | 3.54       |      |        |       |        |      |      |        |        |        |      | C     | 531040 | 10 | 527689 | 23 |
| H, 3H, 4H     | 4.09       | A    | 529062 | 6     | 529060 | 18   | B    | 529063 | 6      | 529060 | 18   |       |        |    |        |    |
| H, 3H, 4H     | 4.55       | A    | 529062 | 6     | 529061 | 20   | B    | 529063 | 6      | 529061 | 20   |       |        |    |        |    |

■ WHEN REPLACING SPEEDOMETER DRIVE GEAR BEFORE TRANSMISSION SERIAL NUMBER S-CH-23.957 ON MODEL 10G AND S-CO-61,800 ON MODEL H ALSO ORDER 1-531039 GOVERNOR SHAFT.

## 1718- CLOCK

|          |  |                     |   |
|----------|--|---------------------|---|
| AC-2122  | CLOCK, ELECTRIC - LHC . . . . .  | 10G, 12G . . . . .  | 1 |
| AC-2337  | CLOCK, ELECTRIC - LHC (INCLUDES CLOCK, MOULDING AND FASTENING PARTS) . . . . . | 14G . . . . .       | 1 |
| AC-2338  | CLOCK, ELECTRIC - RHC (INCLUDES CLOCK, MOULDING AND FASTENING PARTS) . . . . . | 14G . . . . .       | 1 |
| AC-2128  | CLOCK, ELECTRIC - LHC . . . . .  | H . . . . .         | 1 |
| AC-2201  | CLOCK, ELECTRIC - LHC . . . . .  | 3H . . . . .        | 1 |
| AC-2128  | CLOCK, ELECTRIC - RHC . . . . .  | 3H . . . . .        | 1 |
| AC-2339  | CLOCK, ELECTRIC - SPECIAL ORDER EXCEPT Y. . . . .                              | 4H . . . . .        | 1 |
| 527371   | BEZEL, CLOCK - FOR AC-2128. . . . .  | H, 3H . . . . .     | 1 |
| 527372   | BEZEL, CLOCK - SEE BEZEL, INSTRUMENTS - GROUP 1701. . . . .                    | 4H . . . . .        | 1 |
| 527372   | GASKET, BEZEL TO GLASS - RUBBER. . . . .                                       | H, 3H . . . . .     | 1 |
| 527373   | GLASS, CLOCK. . . . .  | H, 3H . . . . .     | 1 |
| 527374   | RETAINER, GLASS. . . . .   | H, 3H . . . . .     | 1 |
| 527374   | DIAL FACE, CLOCK - SEE GROUP 1701 . . . . .                                    | 4H . . . . .        | 1 |
| 533670   | COVER, CLOCK HOLE - EXCEPT Y. . . . .  | 4H . . . . .        | 1 |
| 55-#8-38 | SCREW, TO MOUNTING PLATE . . . . .   | 4H . . . . .        | 3 |
| 527363   | KNOB, CLOCK SET . . . . .  | H, 3H . . . . .     | 1 |
| 527364   | NUT, LOCK 1/16"-64 . . . . .   | H, 3H . . . . .     | 1 |
| 527364   | WASHER, LOCK No. 4. . . . .  | H, 3H . . . . .     | 1 |
| 533166   | CABLE W/FUSE, CLOCK . . . . .  | 4H . . . . .        | 1 |
| 522938   | FUSE, CLOCK - 3 AMP . . . . .  | H, 3H, 4H . . . . . | - |