

MODEL 14G

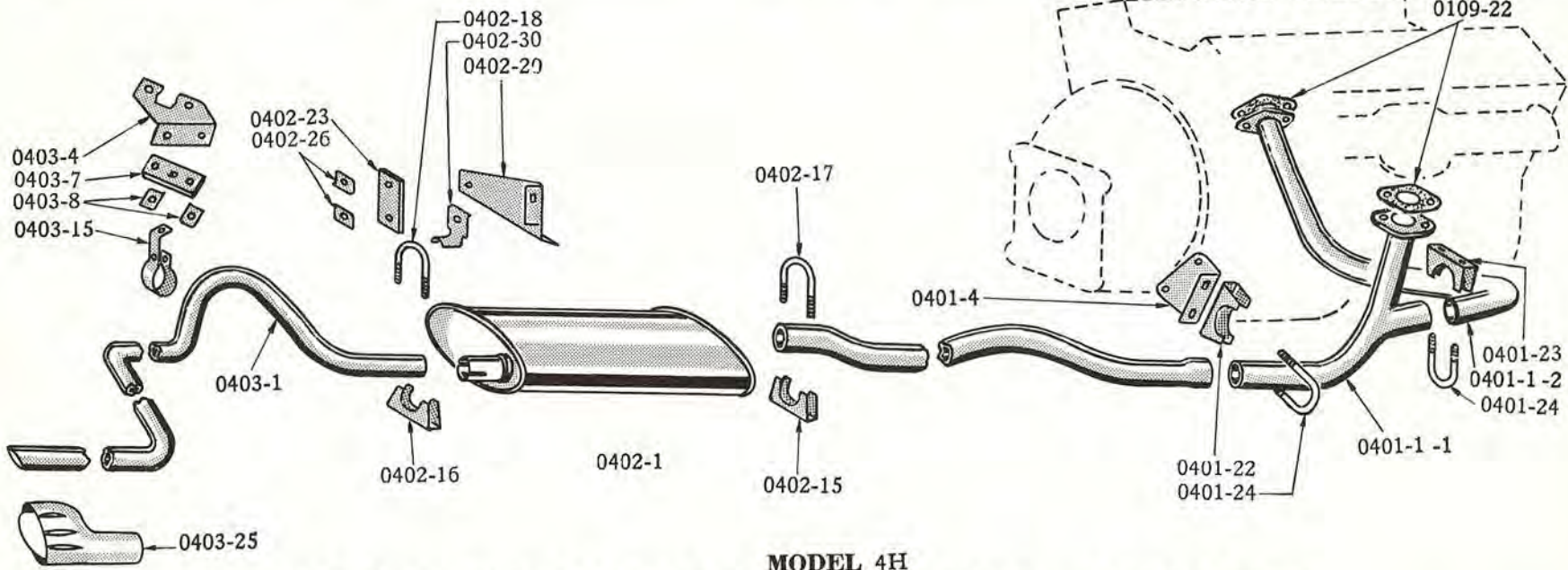

MODEL 4H

EXHAUST PIPE, MUFFLER, OUTLET PIPE and SUPPORTS

EXHAUST

0402

ILLUST. NUMBER	PART NUMBER	CHANGE	DESCRIPTION	MODELS	PER CAR
0401- EXHAUST PIPE AND SUPPORTS (Plate 04-1,2)					
0401-1	530070		PIPE, EXHAUST	10G, 12G	1
0401-1	533109		PIPE, EXHAUST - EXCEPT C-K.	14G	1
0401-1	532392		PIPE, EXHAUST - C-K	14G	1
0401-1-1	530099		PIPE, FRONT RIGHT, EXHAUST.	H, 3H, 4H	1
0401-1-2	530098		PIPE, FRONT LEFT, EXHAUST (CROSSOVER)	H, 3H.	1
0401-1-2	530098		PIPE, FRONT LEFT, EXHAUST (CROSSOVER) EXCEPT C-K.	4H.	1
0401-1-2	532330		PIPE, FRONT LEFT, EXHAUST (CROSSOVER) C-K	4H.	1
0401-1-3	530313		PIPE, REAR, EXHAUST - EXCEPT Y.	H, 3H.	1
0401-1-3	530403		PIPE, REAR, EXHAUST - Y	H, 3H.	1
0401-1-3	533148		PIPE, REAR, EXHAUST - W-F-D-N	4H.	1
0401-1-3	533144		PIPE, REAR, EXHAUST - Y	4H.	1
0401-1-3	532332		PIPE, REAR, EXHAUST - C-K	4H.	1
	203-0622		STUD, TO MANIFOLD 3/8"-16-24X1 3/8"	10G, 12G, 14G	2
	203-0633		STUD, FRONT RIGHT PIPE TO MANIFOLD 3/8"-16-24X2 1/16"	H, 3H, 4H	2
	203-0624		STUD, FRONT LEFT TO MANIFOLD 3/8"-16-24X1 1/2"	H, 3H, 4H	2
	254-06		NUT, HEX, 3/8"-24	10G, 12G, 14G	2
	254-06		NUT, HEX, 3/8"-24	H, 3H, 4H	4
0109-22	680291		GASKET, EXHAUST PIPE FLANGE - STEEL ASBESTOS.	10G, 12G, 14G	1
0109-22	530263		GASKET, EXHAUST PIPE FLANGE - COPPER ASBESTOS	H, 3H, 4H	2
0401-4	526407		SUPPORT, EXHAUST PIPE	10G, 12G, 14G	1
0401-4	530293		SUPPORT, EXHAUST PIPE	H, 3H, 4H	1
	2-0516		BOLT, TO CLUTCH HOUSING 5/16" -24X1"	10G, 12G, 14G, H, 3H, 4H	2
	252-05		NUT, HEX, 5/16"-24.	10G, 12G, 14G, H, 3H, 4H	2
	384-05		WASHER, LOCK 5/16".	10G, 12G, 14G, H, 3H, 4H	2
	361-05		WASHER, PLAIN 5/16"	4H.	2
	380-05		WASHER, LOCK 5/16".	4H.	2
	2-0512		BOLT, THRU CONVERTER HOUSING 5/16"-24X3/4"	H, 3H, 4H	1
	252-05		NUT, HEX, 5/16"-24.	H, 3H, 4H	1
	384-05		WASHER, LOCK 5/16".	H, 3H, 4H	1
	1-0616		SCREW, TO CONVERTER HOUSING 3/8"-16X1"	10G, 12G, 14G, H, 3H, 4H	2
	380-06		WASHER, LOCK 3/8"	10G, 12G, 14G, H, 3H, 4H	2
0401-9	191827		CLAMP, EXHAUST PIPE SUPPORT	10G, 12G, 14G	1
	2-0624		BOLT, CLAMPING 3/8"-24X1 1/2"	10G, 12G, 14G	1
	252-06		NUT, HEX, 3/8"-24	10G, 12G, 14G	1
	----		WASHER, PLAIN 3/8".	10G, 12G, 14G	1
	41X243		WASHER, PLAIN 13/32".	10G, 12G, 14G	1
	380-06		WASHER, LOCK 3/8"	10G, 12G, 14G	1
0401-22	520994		SADDLE, PIPE TO SUPPORT CLAMP	H, 3H, 4H	1
0401-23	908983		SADDLE, PIPES CLAMP	H, 3H, 4H	1
0401-24	520995		"U" BOLT OR CLAMP 5/16"-18 (FOR 520994).	H, 3H, 4H	1
0401-24	908982		"U" BOLT OR CLAMP 5/16"-18 (FOR 908983).	H, 3H, 4H	1
	251-05		NUT, HEX, 5/16"-18	H, 3H, 4H	4
	384-05		WASHER, LOCK 5/16"	H, 3H, 4H	4
0402- MUFFLER (Plate 04-1,2)					
0402-1	519839		MUFFLER - 22" LONG.	10G, 12G	1
0402-1	532577		MUFFLER - 22" LONG.	14G	1
0402-1	530846		MUFFLER - 27 1/2" LONG	H, 3H.	1
0402-1	532576		MUFFLER - 27 1/2" LONG	4H.	1
0402-15	520495		SADDLE, MUFFLER CLAMP (FRONT OF MUFFLER).	10G, 12G, 14G	1
0402-15	520994		SADDLE, MUFFLER CLAMP (FRONT OF MUFFLER).	H, 3H, 4H	1
0402-16	525141		SADDLE, MUFFLER CLAMP (REAR OF MUFFLER)	14G	1
0402-16	520495		SADDLE, MUFFLER CLAMP (REAR OF MUFFLER)	4H.	1
0402-17	520494		"U" BOLT OR CLAMP 5/16"-18	10G, 12G, 14G	1
0402-17	531446		"U" BOLT OR CLAMP 5/16"-18	H, 3H, 4H	1
0402-18	525142		"U" BOLT OR CLAMP 1/4"-20.	14G	1
0402-18	520494		"U" BOLT OR CLAMP 5/16"-18	4H.	1
	251-05		NUT, HEX, 5/16"-18.	10G, 12G, H, 3H, 4H	2
	251-04		NUT, HEX, 1/4"-20	14G	2
	384-05		WASHER, LOCK 5/16"	10G, 12G, H, 3H, 4H	2
	384-04		WASHER, LOCK 1/4"	14G	2

0402

EXHAUST

ILLUST. NUMBER	PART NUMBER	CHANGE	DESCRIPTION	MODELS	PER CAR
0402- MUFFLER-Cont'd. (Plate 04-1,2)					
0402-20	526681		BRACKET, MUFFLER AND BODY SUPPORT	10G, 12G, H, 3H.	1
0402-20	532503		BRACKET, MUFFLER.	14G, 4H.	1
	----		RIVET, TO FRAME 5/16"X13/16"	10G, 12G, H, 3H.	3
	650-058		SCREW, TO FRAME 5/16"X1/2"	14G, 4H.	1
	2-0614		BOLT, TO FRAME 3/8"-24X7/8"	14G, 4H.	1
	252-06		NUT, HEX 3/8"-24.	14G, 4H.	1
	----		WASHER, PLAIN 3/8"	14G, 4H.	1
	380-06		WASHER, LOCK 3/8"	14G, 4H.	1
0402-23	526460		STRAP, MUFFLER SUPPORT (REAR OF MUFFLER).	10G, 12G, 14G, H, 3H, 4H	1
	2-0516		BOLT, TO BRACKET AND SUPPORT 5/16"-24X7/8"	10G, 12G, 14G, H, 3H, 4H	2
	252-05		NUT, HEX, 5/16"-24.	10G, 12G, 14G, H, 3H, 4H	2
0402-26	526347		WASHER, SPECIAL	10G, 12G, 14G, H, 3H, 4H	2
	380-05		WASHER, LOCK 5/16"	10G, 12G, 14G, H, 3H, 4H	2
0402-30	526459		SUPPORT, MUFFLER (REAR OF MUFFLER).	10G, 12G, 14G, H, 3H, 4H	2
0402-32	526461		CLAMP, MUFFLER (REAR OF MUFFLER).	10G, 12G	1
0402-32	526680		CLAMP, MUFFLER (REAR OF MUFFLER).	H, 3H.	1
	1-0616		BOLT, CLAMPING 3/8"-16X1".	10G, 12G, H, 3H.	1
	191715		NUT, SPECIAL 3/8"-16.	10G, 12G, H, 3H.	1
	191714		WASHER, SPECIAL 3/8"	10G, 12G, H, 3H.	1

0403- MUFFLER OUTLET PIPE AND HANGERS (Plate 04-1-2)

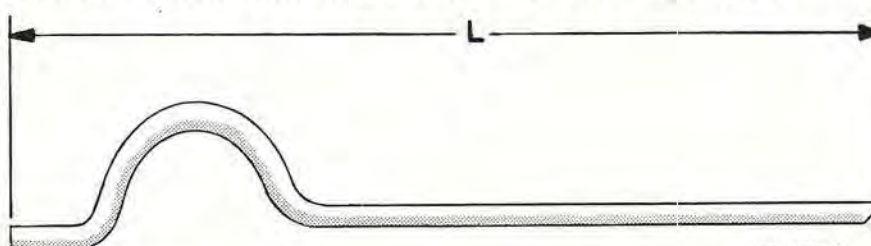

ILLUST. NUMBER	PART NUMBER	DESCRIPTION	LENGTH	MODELS	PER CAR
0403-1	526105	PIPE, OUTLET.	58 11/16"	10G, 12G	1
0403-1	532387	PIPE, OUTLET - W-F.	56 3/8"	14G	1
0403-1	532395	PIPE, OUTLET - C-K.	54 7/8"	14G	1
0403-1	534205	PIPE, OUTLET - D-N.	54 3/4"	14G	1
0403-1	529418	PIPE, OUTLET.	58 1/8"	H, 3H.	1
0403-1	532516	PIPE, OUTLET - W-F-Y.	56 3/8"	4H.	1
0403-1	532333	PIPE, OUTLET - C-K.	54 7/8"	4H.	1
0403-1	534208	PIPE, OUTLET - D-N.	54 3/4"	4H.	1
0403-4	526488	BRACKET, OUTLET PIPE HANGER		10G, 12G, H, 3H.	1
0403-4	532463	BRACKET, OUTLET PIPE HANGER		14G, 4H.	1
	2-0512	SCREW, TO FRAME 5/16"-24X5/8"		10G, 12G, H, 3H.	2
	650-058	SCREW, TO FRAME 5/16"-24X1/2"		14G, 4H.	1
	380-05	WASHER, LOCK 5/16".		10G, 12G, H, 3H.	2
0403-7	526460	STRAP, OUTLET PIPE HANGER		10G, 12G, H, 3H.	1
0403-7	517914	STRAP, OUTLET PIPE HANGER		14G, 4H.	1
	2-0516	BOLT, TO CROSSMEMBER 5/16"-24X1"		10G, 12G, 14G, H, 3H, 4H	2
	252-05	NUT, HEX, 5/16"-24.		10G, 12G, 14G, H, 3H, 4H	2
	526347	WASHER, SPECIAL		10G, 12G, H, 3H.	1
0403-8	512752	WASHER, SPECIAL		14G, 4H.	2
	380-05	WASHER, LOCK 5/16"		10G, 12G, 14G, H, 3H, 4H	2
0403-15	532471	HANGER, OUTLET PIPE - W-F		14G	1
0403-15	533238	HANGER, OUTLET PIPE - C-K		14G	1
0403-15	534214	HANGER, OUTLET PIPE - D-N		14G	1

EXHAUST

0403

ILLUST. NUMBER	PART NUMBER	CHANGE ✓	DESCRIPTION	MODELS	PER CAR
0403- MUFFLER OUTLET PIPE AND HANGERS-Cont'd.					
(plate 04-1-2)					
0403-15	532466		HANGER, OUTLET PIPE - W-F-Y	4H.	1
0403-15	533239		HANGER, OUTLET PIPE - C-K	4H.	1
0403-15	534168		HANGER, OUTLET PIPE - D-N	4H.	1
	2-0516		BOLT, TO STRAP 5/16"-24X1"	14G, 4H.	1
	252-05		NUT, HEX 5/16"-24	14G, 4H.	1
	370-05		WASHER, PLAIN 5/16"	14G, 4H.	1
	380-05		WASHER, LOCK 5/16"	14G, 4H.	1
	----		BOLT, CLAMP 3/8"-24X1 1/4"	14G, 4H.	1
	252-06		NUT, HEX 3/8"-24	14G, 4H.	1
	----		WASHER, PLAIN 3/8"	14G, 4H.	1
	380-06		WASHER, LOCK 3/8"	14G, 4H.	1
0403-19	526486		SUPPORT, OUTLET PIPE HANGER	10G, 12G, H, 3H.	1
0403-22	526679		CLAMP, OUTLET PIPE HANGER SUPPORT	10G, 12G	1
0403-22	526485		CLAMP, OUTLET PIPE HANGER SUPPORT	H, 3H.	1
	----		BOLT, CLAMPING 3/8"-24X1 1/4"	10G, 12G, H, 3H.	1
	252-06		NUT, HEX, 3/8"-24	10G, 12G, H, 3H.	1
	380-06		WASHER, LOCK 3/8"	10G, 12G, H, 3H.	1
0403-25	AC-1851		EXTENSION, OUTLET PIPE - CHROME	} INCLUDES FASTENING PARTS	10G, 12G, 14G, H, 3H, 4H
0403-25	AC-1868		EXTENSION, OUTLET PIPE - STAINLESS STEEL		10G, 12G, H, 3H.